

UAV engine EFI installation manual

-3w56 engine
Installation Manual

V1.7

COPY RIGHTS ECOTRONS LLC

ALL RIGHTS RESERVED

[Http://www.ecotrons.com](http://www.ecotrons.com)

Note: If you are not sure about any specific details,
please contact us at info@ecotrons.com.

Index	Page	Revision	Date	Note
1		First Edition	5.3.2015	V1.1
2		Second Edition	12.6.2015	V1.2
3		Third Edition	5.9.2016	V1.3
4		Fourth Edition	6.23.2016	V1.4
5		Fifth Edition	1.20.2017	V1.5
6		Sixth Edition	4.16.2017	V1.6
7		Seventh Edition	5.11.2017	V1.7

Content

Introduction	5
Chapter 1 EFI installation	8
1.1 Remove the stock carburetor and install the throttle body	8
1.2 Install the fuel supply system.....	9
1.3 Install the cylinder head temperature sensor (CHT).....	11
1.4 Install the intake air temperature sensor (IAT)	12
1.5 Install ignition system	13
1.5.1 Connect the ECU harness to the stock CDI and pickup sensor	13
1.5.2 Use Ecotrons CDI for ignition control.....	14
1.6 Servo motor installation.....	17
1.6.1 Parameters of servo motor	17
1.6.2 Installation of servo motor	18
1.7 The connection of TPS signal.....	25
1.8 Control Servo motor	25
1.9 Install the fuel injector and connect the connector	26
1.10 Connect the harness to 12V battery	27
1.11 Mount the ECU.....	28
1.12 Mount the Harness	31
1.13 Optional prime switch function.....	33
Chapter 2 ALM-ECU integration for tuning	34

2.1 Install the wideband O2 sensor	34
2.2 Connect the ALM to ECU	34
2.2.1 Connect the ALM to ECU via Performance switch.....	34
2.2.2 Connect ALM-CAN to ECU via CAN bus.....	36
Chapter 3 Broadcast protocol.....	37
3.1 ECU broadcast data list on RS232	37
3.2 ECU broadcast data list on CAN bus.....	38
3.2.1 The CAN Baud rate setting of ECU	38
3.2.2 Can bus broadcast	39
Chapter 4 Communication Settings	41
4.1 COM communication mode	45
4.2 USB communication mode	46
4.3 CAN communication mode.....	48
4.4 Ethernet communication mode	49
Chapter 5 Initial test after the installation.....	51
Chapter 6 How do we know the fuel injector flow rate	55
Chapter 7 UAV EFI Maintenance	57

Introduction

UAV EFI for 3W engine is an Electronic Fuel Injection conversion kit for the UAV engine. It is a bolt-on EFI kit to a lot of small engines. For example, 3W-28, 3W-56, etc. We can supply the suitable EFI kit for most of UAV engines. The displacement of the engines can be in the range of 20cc to 300cc, and even larger engines.

This UAV EFI kit has below features:

- Electronic fuel injection (EFI)
- Quick engine start even at cold temperatures
- More power and torque than the carbureted version
- High fuel efficiency and low carbon emissions
- OBD - on board diagnosis
- Performance tuning for advanced users.
- Altitude compensations
- Transient fuel compensations
- Servo motor control (optional)
- Ignition control (optional)

Parts:

1. ECU
2. Harness (including the connectors)
3. Throttle Body
 - Throttle body
 - Servo motor(included)
 - TPS sensor(optional)
 - Fuel injector (mounted on the throttle body)
4. Fuel pump assembly
 - Rotary fuel pump with pressure regulator (outside of the tank, 25L/h)
5. Baro sensor (integrated in ECU)
6. Engine temperature sensor
7. Intake air temperature sensor
8. Ecotrons CDI - ECU controlled (optional, you can use your own CDI).
9. Serial communication cable (to a computer)
10. USB adaptor - included

11. CD for tuning software (downloadable from our website)

Note: The kit requires a 12V battery by default.

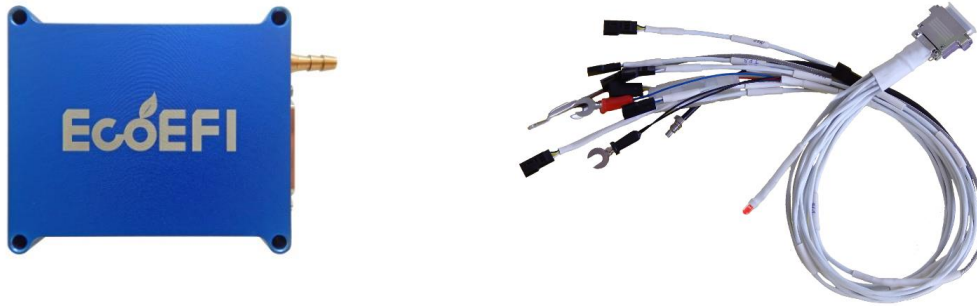

37-pin ECU and Harness



Fuel pump group



Throttle body with TPS and Servo motor

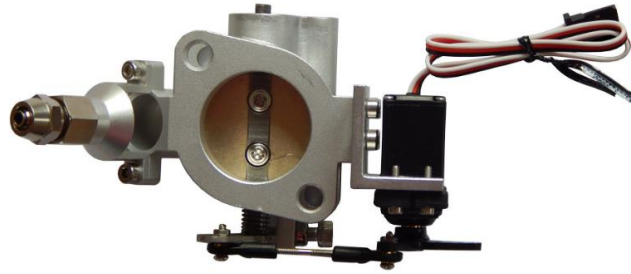

Throttle body with Servo motor



Engine temperature and intake air temperature



Ecotrons CDI Unit

Chapter 1 EFI installation

1.1 Remove the stock carburetor and install the throttle body

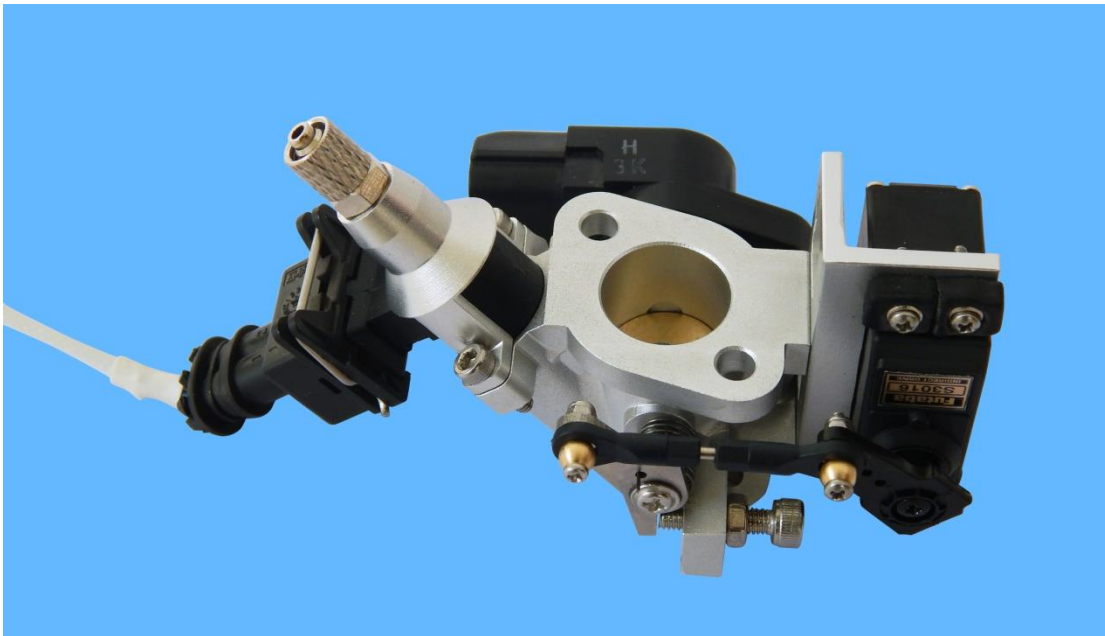

Note: Ecotrons Small throttle body is designed to replace the stock carburetor and has the same or similar spacing as the carburetor, so that you can bolt on the throttle body. Ecotrons throttle body is designed to mount the Futaba servo motor easily. So the complete throttle body / servo is compact and light.

Ecotrons Small throttle body is designed to mount Ecotrons' small engine injectors. It comes with the injector fittings and thread-on fuel lines.

And we also have 14mm, 18mm, 22mm, 28mm throttle body for UAV engines, The injector flow rates: 30g/min, 38, 60, 80, 128, 190, 248g/min etc. So we can provide the UAV EFI kit for different engines with different displacement.

Please don't remove the **limit screw** from throttle body.

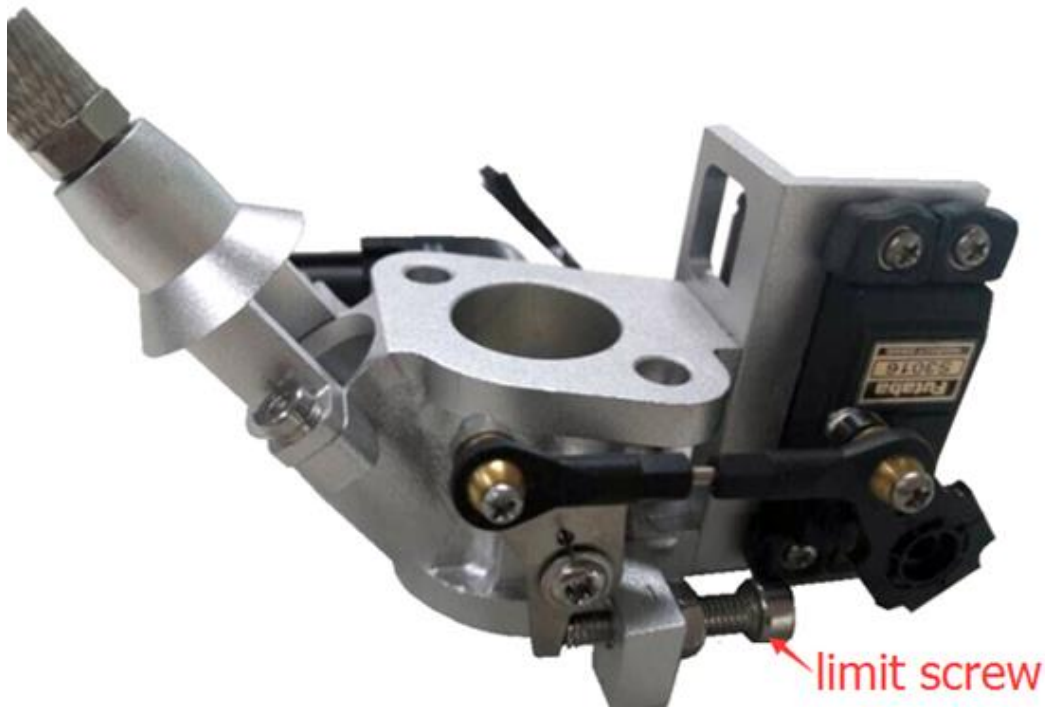

Some engines, you can use the throttle body to replace the carburetor completely, and for some engines, you need make the adapter to bolt on the throttle body.

1.2 Install the fuel supply system

Customers have to find a good location to install the fuel pump. By default, the fuel pump should be lower than the fuel tank.

The fuel feed inlet in the tank should be submerged in the fuel all the time. There should be an inline fuel filter, which is not included in the kits. You need to find one suitable fuel filter to be installed.

Note: The EFI has a fuel pressure regulator which requires a fuel return line back to the fuel tank.

This assembly Must be: Below the fuel tank to allow proper fuel flow.

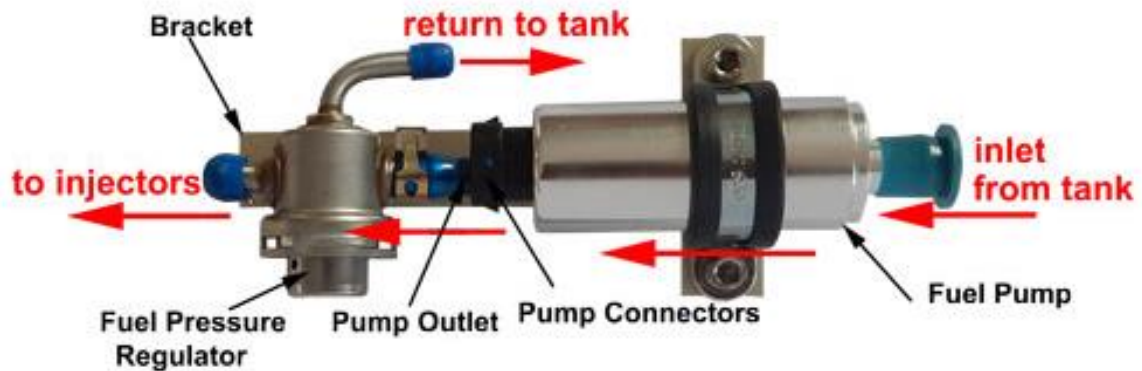
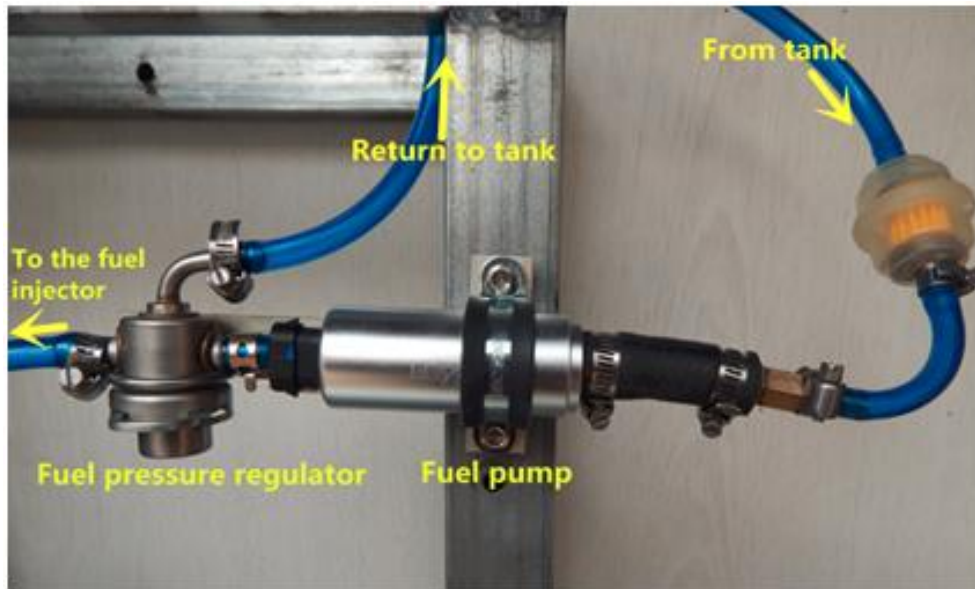

Note: The fuel pump bracket is optional, and the fuel pump bracket is not included in the default UAV EFI kits.

The fuel pump is a rotor type, has 25L/h flow rate. It has only limited sucking power. If there are too many air bubbles in the fuel lines, the pump will not work.

Connect the connector to the fuel pump:

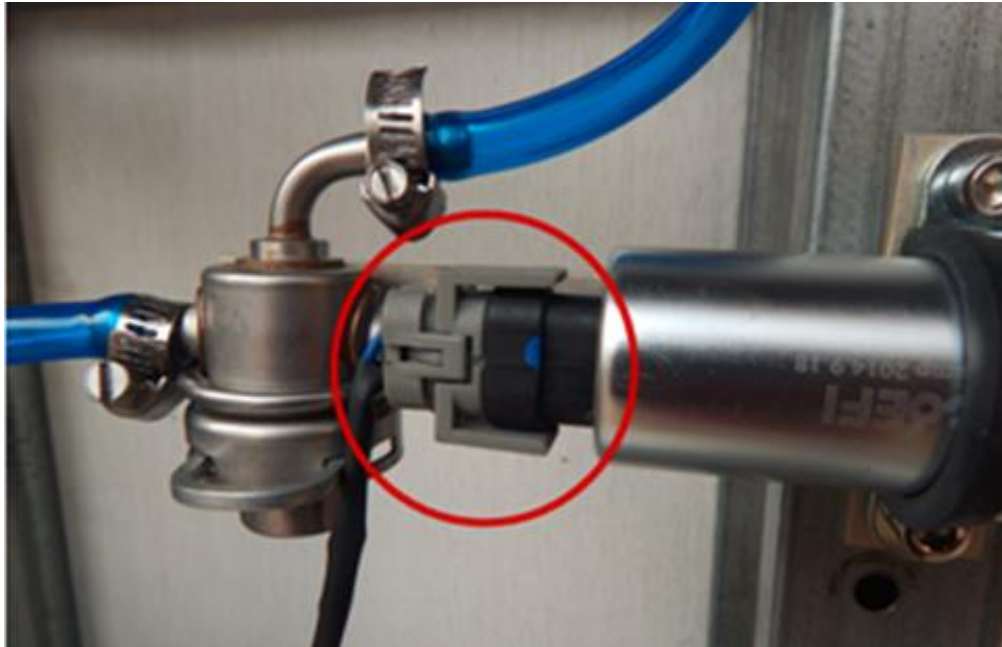

Note: Air must be FULLY purged from all fuel lines before attempting startup. Any air bubbles will impede fuel flow and cause reduced performance or “No Start “condition.

1.3 Install the cylinder head temperature sensor (CHT)

Find the CHT Sensor in the harness.

It should have this nut and bolt attached.

Mount them in the corresponding hole on the Right Cylinder cooling fin as shown here.

Be sure this is a secure connection as it is the only Engine Temp. Sensor we read.

The CHT sensor must be installed at the cylinder head, closed to spark plug. If you can

place it under the spark plug, it is also OK.

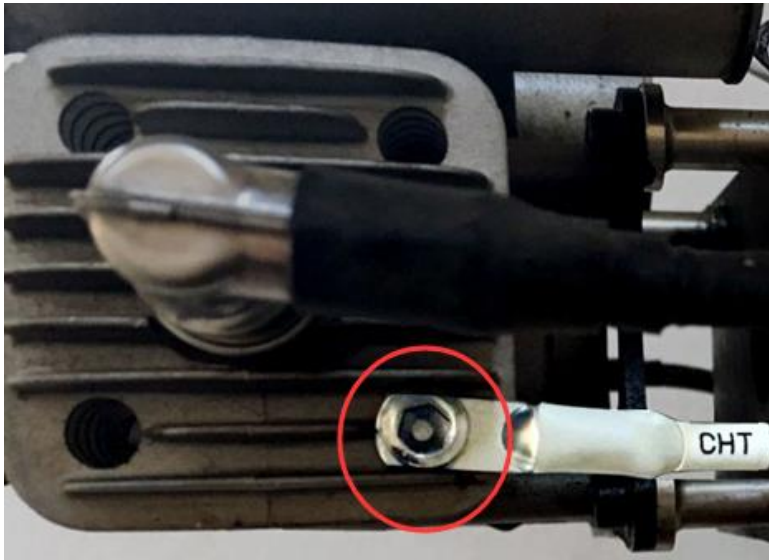

Note: The best choice is that CHT's wiring is on the lee side. Do strain it as far as possible to prevent the shaking caused by the wind or gravitation when you fix the wire of CHT. Besides, the wire does not be bended repeatedly when CHT is installed.

1.4 Install the intake air temperature sensor (IAT)

Please install the intake air temperature sensor in the air box, or put the IAT in the air if there is no air box. And make sure there is no twisting stress on the IAT wire after finish IAT installation.



1.5 Install ignition system

1.5.1 Connect the ECU harness to the stock CDI and pickup sensor

For 3W engines, you can choose that the EFI only controls the fuel injection, and keep the stock CDI system, you only need to tap the stock pick-up signal wire to ECU harness.

There are 4 wires from the stock Hall sensor. They are the red, yellow, blue, and black wires. The red wire is power+, and the black wire is ground. There are two signal wires, blue and yellow wires.

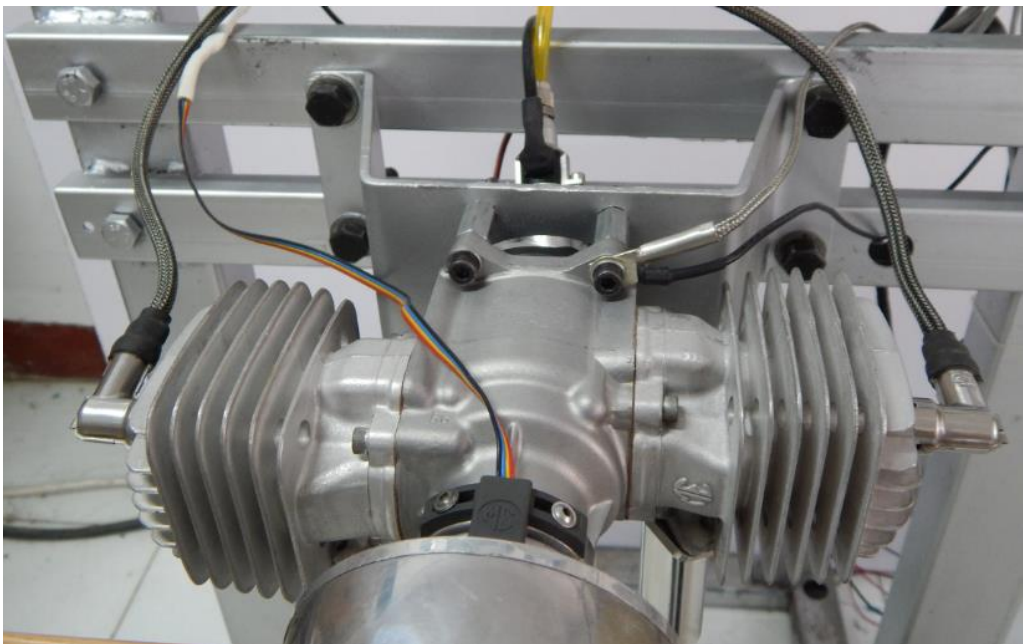

We provide the connector to connect the stock hall sensor and ECU harness.

There are 2 wires from the connector. They are the green, and white wires. The green wire is GND (ground), and the white wire is signal.

The connector connects to the harness connector labelled "HALL SENSOR".

How to connect the connector to stock pickup sensor?

The green (GND) wire from connector connects to the black wire of stock pickup sensor.

The white (signal) wire from connector connects the blue wire of stock pick-up sensor.

The below picture is the connections of harness, connector, and stock pick-up sensor.

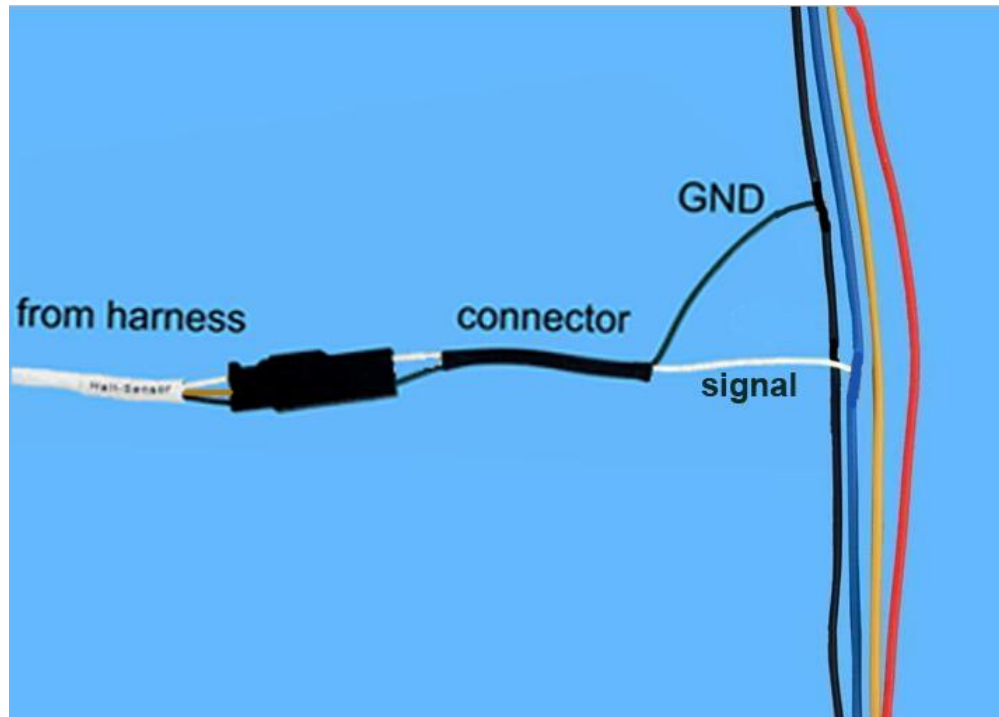

Note: If the ECU controls the fuel injection and you use the stock ignition module, you just need to connect the connector wire to ECU harness and stock pickup wires, like above pictures.

1.5.2 Use Ecotrons CDI for ignition control

You can use ECU to control ignition module with Ecotrons CDI and stock pickup sensor.

a. Connect the pickup connector from harness to the pickup sensor

For 3W series engines, EFI can control both the fuel injection and ignition. You can choose use the stock pick-up sensor and use Ecotrons CDI to control ignition system, but you need use the connector adaptor which was provided from us.

There are 4 wires from the stock Hall sensor. They are the red, yellow, blue, and black wires. The red wire is power+, and the black wire is ground. There are two signal wires, blue and yellow wires.

There are 3 wires from the adapter. They are the green, white, and yellow wires. The yellow wire is VCC (5V), the green wire is GND (ground), and the white wire is signal.

The adapter connects to the harness connector labelled “HALL SENSOR”.

How to connect the adapter to stock pickup sensor?

The green (GND) wire from adapter is connected to the black (GND) wire of stock pickup sensor.

The white (signal) wire from adapter is connected the blue (labeled “signal 1”) wire of stock pick-up sensor.

The yellow (VCC) wire from adapter is connected to the red (VCC) wire of stock pick-up sensor.

The below picture is the connections of harness, adapter, and stock pick-up sensor.

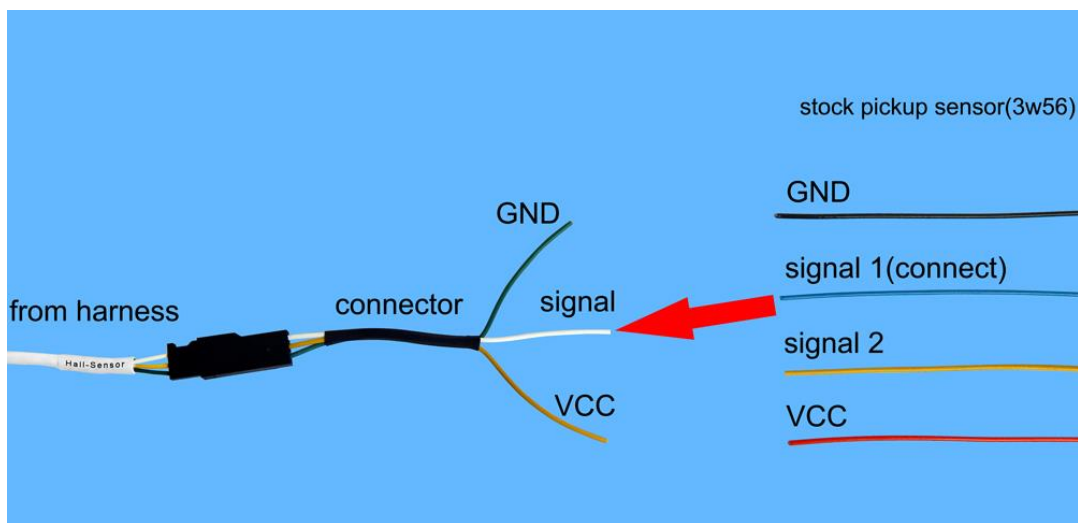

b. Connect the CDI connector from harness to Ecotrons CDI

Connect the “CDI Power” from ECU harness to the red connector of Ecotrons CDI.

Connect the “CDI Ctrl” from ECU harness to the black connector of Ecotrons CDI.

The connector which is labeled “Tachometer” can be connected to your own Tachometer.

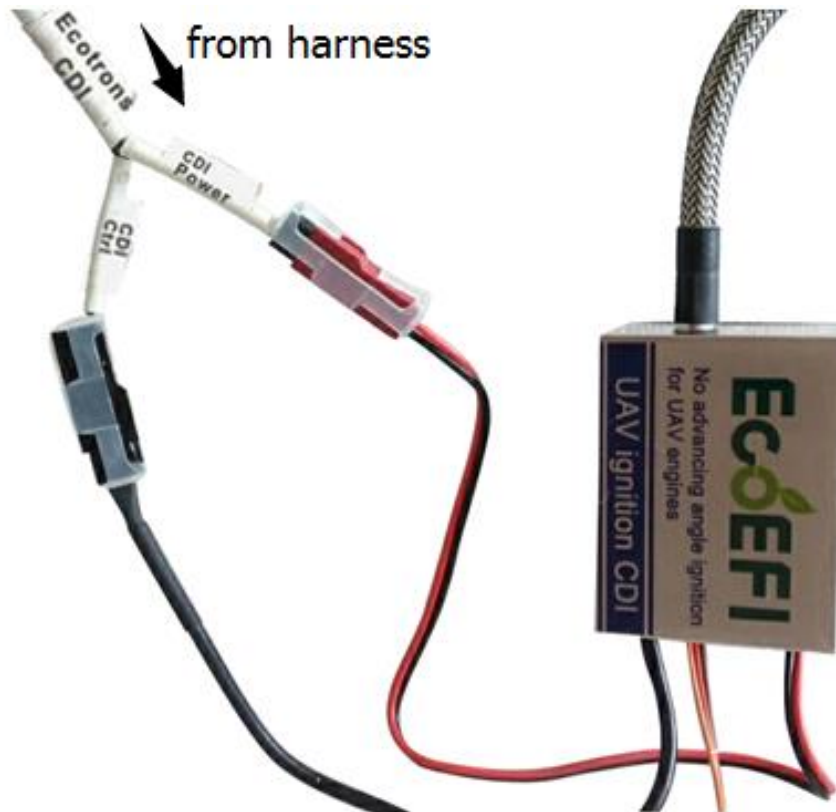

Note:

- 1) CDI Power: it gives Ecotrons CDI power.
- 2) CDI Ctrl: ECU outputs to control Ecotrons CDI.
- 3) Do NOT plug the connectors in the wrong direction.

1.6 Servo motor installation

1.6.1 Parameters of servo motor

The servo motor is installed on the throttle body for an UAV EFI system by default. It is to open and close the throttle valve, as the throttle actuator.

We use the Futaba S3016 servo motor in our EFI system.



Futaba servo S3016:

Type	Analog Servo
Torque	4.8V: 47.0 oz-in(3.38kg-cm) 6.0V: 58.0oz-in(4.18kg-cm)
Speed	4.8V: 0.25 sec/60 6.0V: 0.20 sec/60
Weight	1.20 oz(34.0 g)
Size	length: 1.22 in(31.0 mm) width: 0.63 in(16.0 mm) height:1.21 in(30.7mm)

There are three wires in servo. The black is ground, the white is the control signal line, and the red is the power line, which is 5V.



1.6.2 Installation of servo motor

Note: Usually we install the Servo motor on the throttle body, you don't need re-install it.

If you need install the servo motor, please see the following information as reference.

The Servo is controlled by the “auto-pilot” of the UAV, via a PWM signal. The PWM duty cycle is inversely proportional to the throttle.

What's the best range of rotation angle when the servo motor is installed?

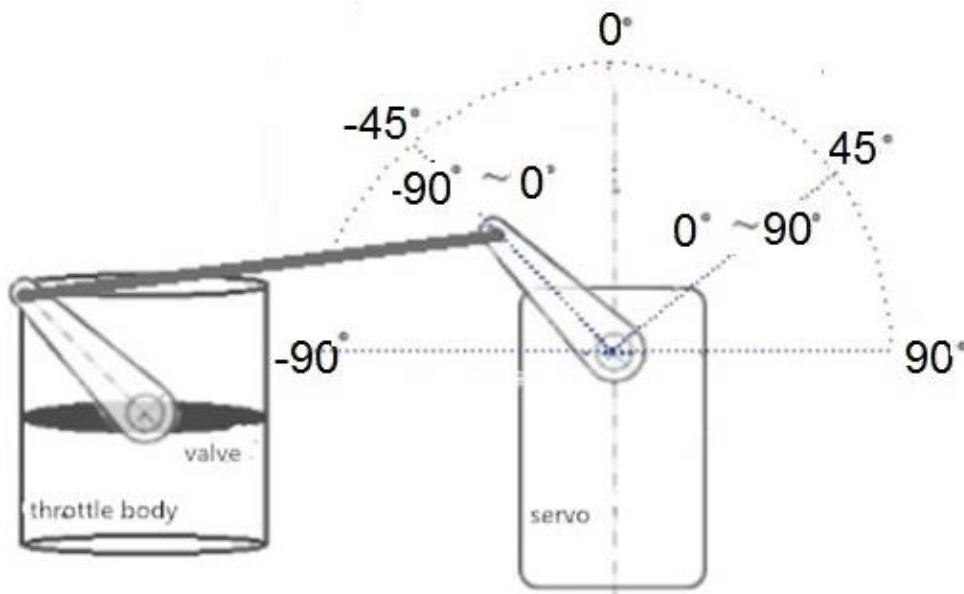

The throttle is closed

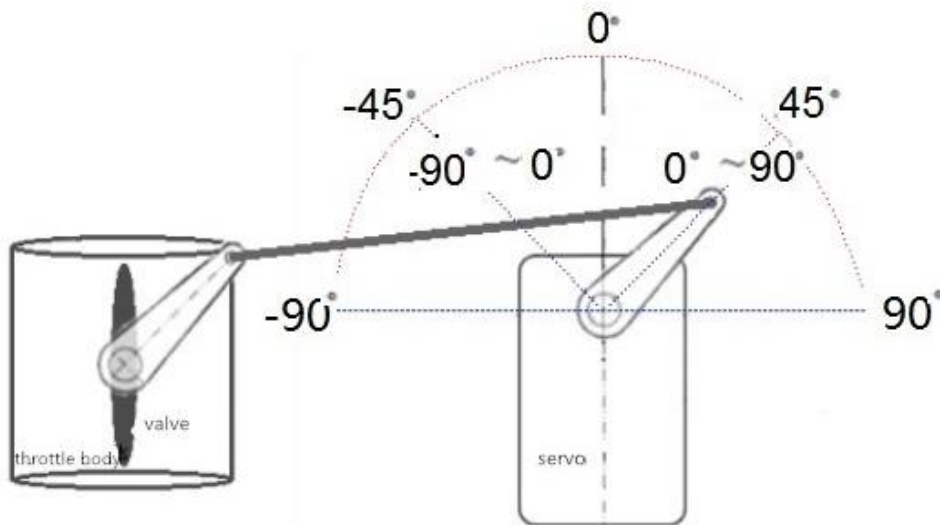

The throttle is fully opened

Note: You would assume the total rotation angle of a servo motor is 0-180 degrees; but actually, the servo rotation angle is about 90 degrees when used to control the throttle.

As shown in the above picture, the servo angular positions of -45 degree to 45 degree are corresponding to throttle position of 0 to 180 degrees.

Example of installation:

We use the Futaba S3016 servo motor in our EFI system.



The simplest method for servo motor installation:

By default, the servo rotation travelling is about 180 degrees. But we are going to only use half of that travelling range. Try to manually rotate the servo arm to find the upper and lower mechanical stop positions. It is about 180 degree travelling range.

Note: Don't rotate more than 180 degrees with too much force; otherwise it could damage the servo motor. (The RED circle in the picture is the reference point).

0 position of the servo arm.

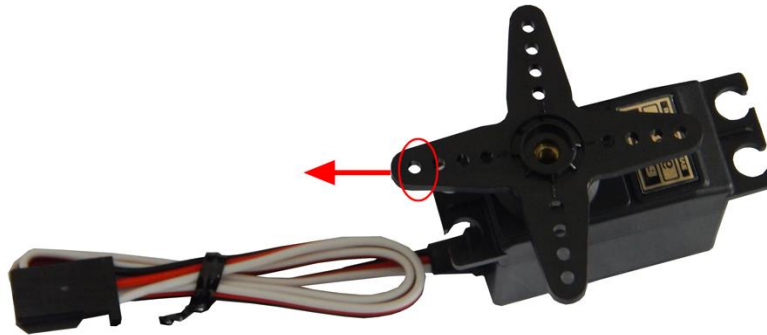

About 180 degree position of the servo arm:

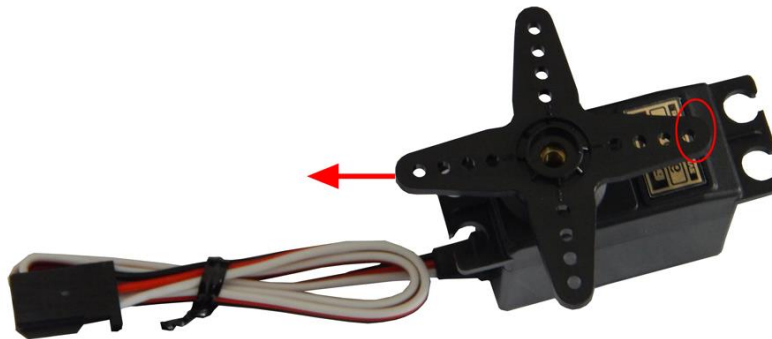

1. Make sure the servo can rotate freely between 0-180 degrees, then position the reference point (The **RED** circle) in the middle of the 180 degree range. That means, from that position, it can go 90 degrees either way. This position is going to be the 0 degree position.

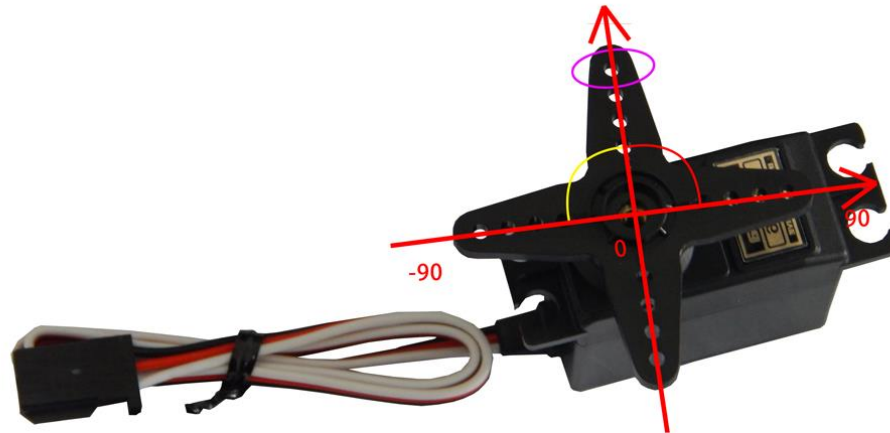

2. Install the servo on the throttle body.

Before you connect the servo and the throttle, open the throttle valve about 40 degree, where the throttle opening is about 50%. Note: the total throttle valve turning angle might be only 80 degrees. Keep the throttle about 50% opening, and connect the throttle valve arm to the servo arm with the servo link rod. By doing this, the servo 0 degree reference position is corresponding to the 50% of throttle opening. The concept of this is because the servo will be moved both ways, from the 0 degree position.

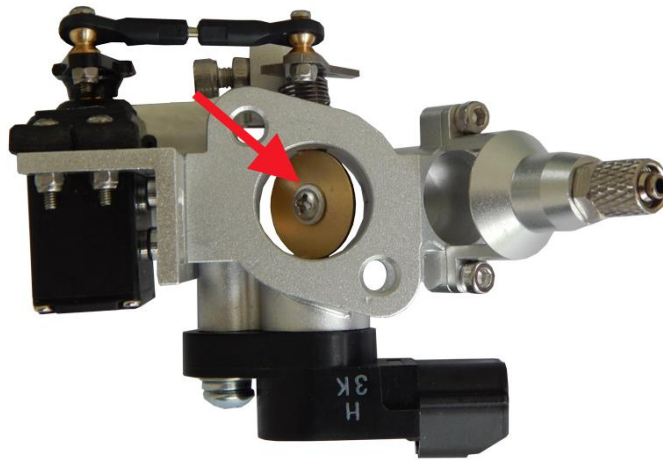

3. After linking the servo to the throttle valve, try to move the servo both ways, and make sure the throttle valve is opening and closing. You shall notice that the servo is about -40 degrees when throttle valve is fully closed, and it is about 40 degrees when the throttle valve is fully opened. This will ensure that the servo will move within its reasonable range when the throttle is changing between 0-100%.

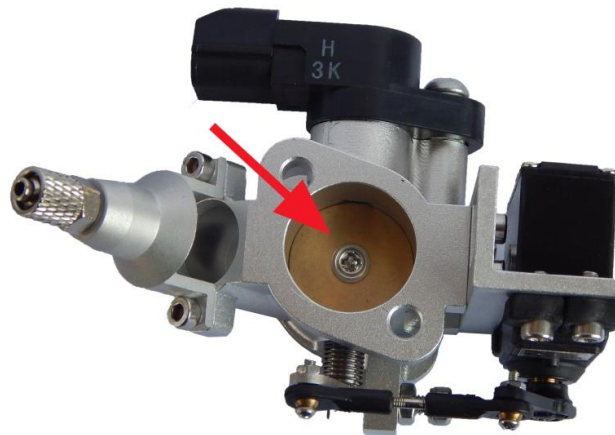

Throttle Valve is fully closed

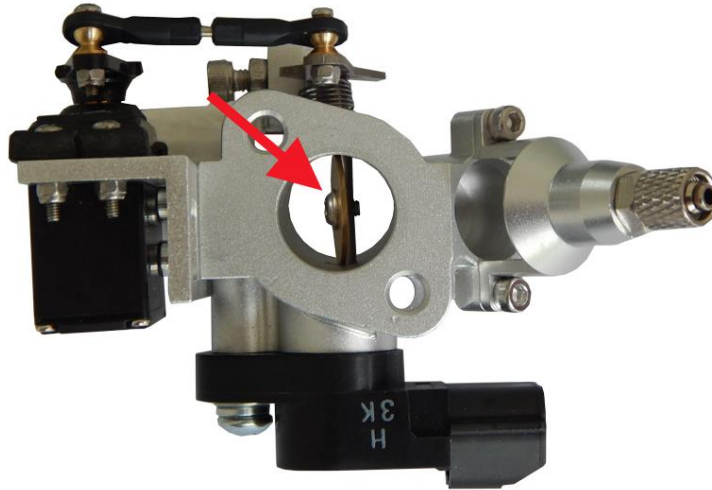

Throttle Valve is fully opened

Note: the throttle idle position can be adjusted by the mechanical idle stop.

Finally, fix and tighten everything.

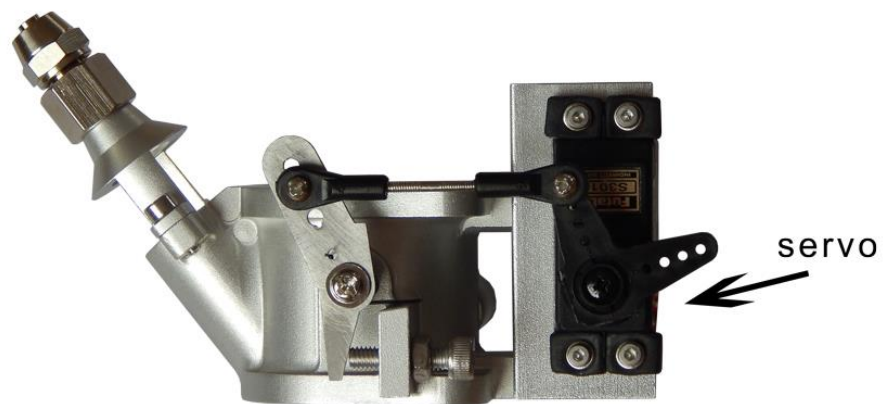

Warning:

For the servo installation, you have to make sure the throttle and servo are both synchronous with one another.

When the servo arm moves, the throttle valve arm also should moves. If the servo arm moves, but the throttle valve arm doesn't move, the throttle valve will not be opened; this will not allow the engine to run well when you add the "throttle" via your "auto-pilot" of the UAV.

1.7 The connection of TPS signal

For most engines, we provide the TPS sensor usually. So you need to connect the TPS connect to the TPS sensor which is mounted on the throttle body.

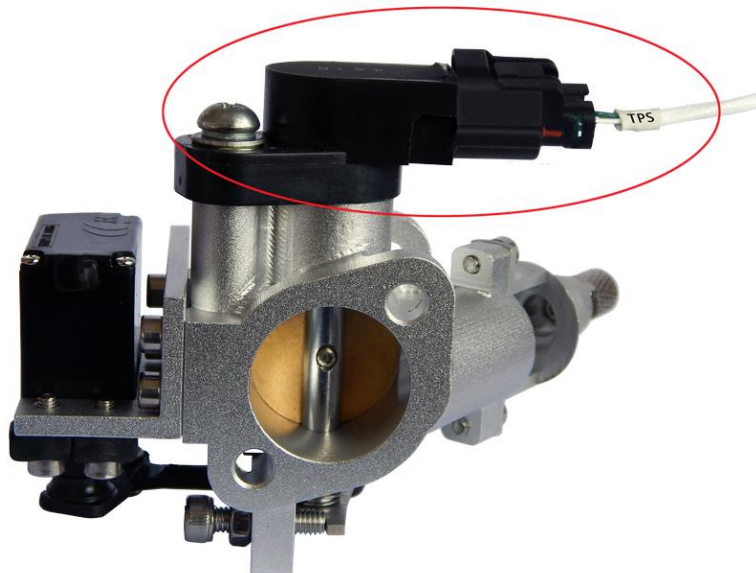

1.8 Control Servo motor

Note: It will be the custom UAV engine EFI kit if you want our ECU to control servo motor, please contact us to get the custom kit.

The "auto-pilot" from customer needs to send the command to ECU.

- 1) The default duty cycle of servo control PWM signal is 20ms.
- 2) The default pulse width is 0.5-2.5ms, but if the pulse is 2.5ms, the servo will rotate in 360 degrees. So the correct range is 0.6-2.3ms to protect the servo motor.
- 3) The rotation angle is about 180 degrees, so please don't rotate the servo more than 180 degrees.
- 4) Do not incorrectly connect the wires of the servo motor.

1.9 Install the fuel injector and connect the connector

Here you should also attach and secure the fuel line to the connector shown adjacent the injector connector.

Make sure this is a "secure connection" but avoid over tightening this fitting it is cast aluminum and somewhat fragile

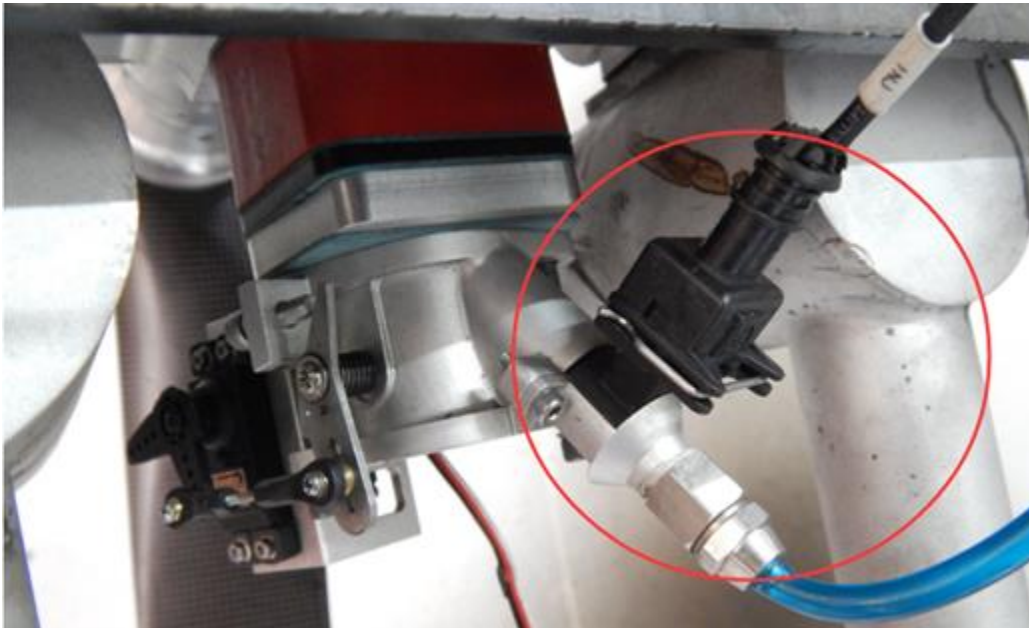

1.10 Connect the harness to 12V battery

The 12V battery is needed in the UAV EFI kit. You can choose the 12V lithium battery is light weight, Small volume, good performance.

Note: the red is to the positive of battery; the black is to the negative of battery. There is one manual switch on the power wire; you can use this switch to power on EFI, or power off.



Note: connect the negative of battery to the engine block. All ground wires should be common.

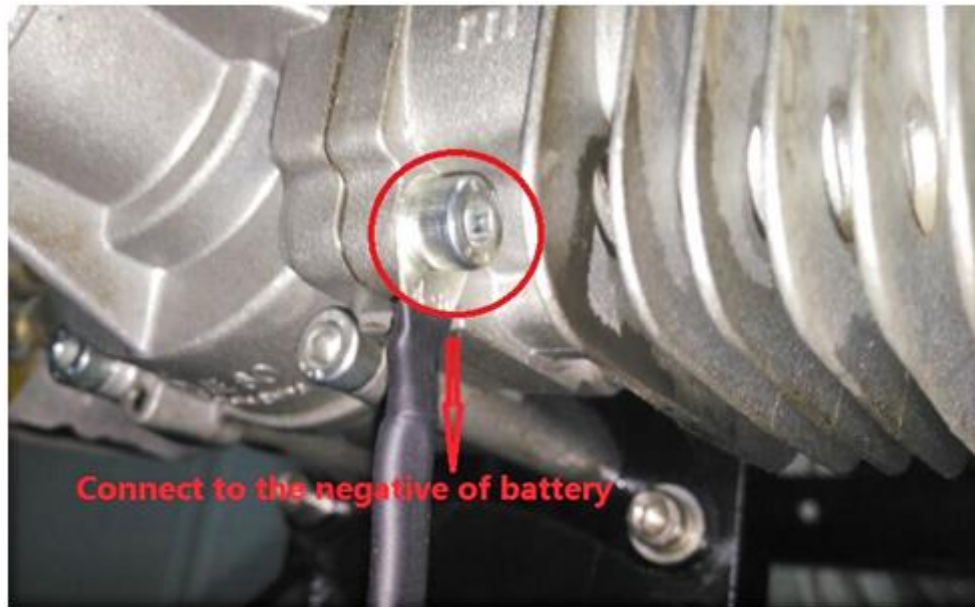

Note: The black wire goes to negative of battery.

1.11 Mount the ECU

Find a safe place to mount the ECU, avoid the severe vibration and severe hot conditions. Do not expose it to water / fluids. This ECU is NOT water proof.

Connect the Main Harness to the ECO/EFI (ECU) and secure it with two small harness screws located on the harness base connector.

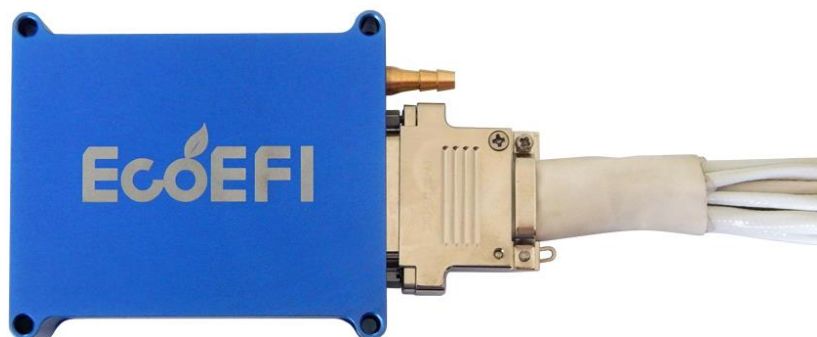

Please notice to tighten the screw of harness after ECU connects harness.

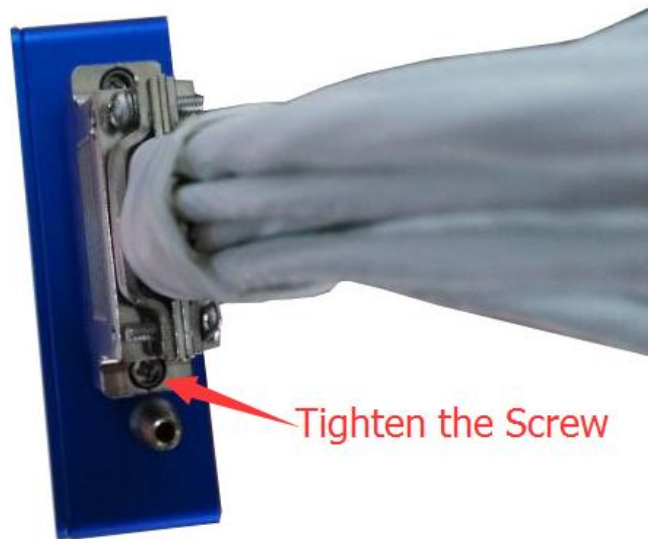

Parameters of ECU

- Aluminum case, light weight: 120 gram total;
- Mini size: 78x64x20mm dimensions;
- mini-D connector (37 pin);
- built-in baro sensor, automatic altitude compensation;
- controlling 1 or 2 cylinder engines, both fuel injection and ignition controls;
- CAN bus capable;

Pictures of ECU

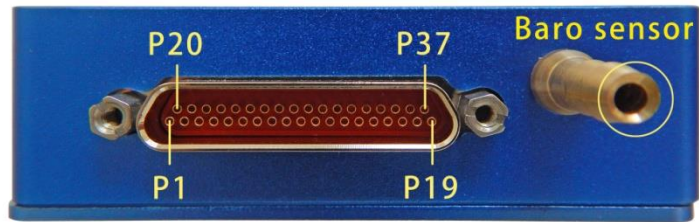

Definition of pins:

Number	Define	Color	instructions
1	INJ1	White	Fuel injector # 1 low side driver output
2	KEYSW	Blue	Fuel injector # 1 power output
3	GND	Black	Power ground
4	GND	Black	Power ground
5	ROUT	White	Relay low side driver output
6	KEYSW	Blue	Relay power output
7	GND	Green	CKP(pick-up) sensor ground
8	CKP	White	Crank Position sensor input (Pickup)
9	VCC	Yellow	Power of Hall sensor
10	CANL	Green	CANL

11	CANH	Yellow	CANH
12	MAP	White	Intake manifold pressure sensor (Optional)
13	RXD	White	Goes to RXD of RS232
14	TXD	Yellow	Goes to TXD of RS232
15	GND	Green	RS232 ground
16	PWMIN	White	Servo motor PWM input
17	PWMOUT	White	Servo motor control PWM output (Optional)
18	GND	Green	Servo motor ground
19	VCCM	Yellow	Power of servo motor (Optional)
20	NULL	----	-----
21	NULL	----	-----
22	GNDP	Blue	Power ground
23	GNDP	Red	Power ground
24	KEYSW	Blue	Power of Mil-Lamp
25	Mil-lamp	White	Mil-Lamp
26	12V+	Blue	ECU power input
27	12V+	White	ECU power input
28	CHT	White	Cylinder head temp sensor input
29	GND	Green	CHT ground
30	GND	Green	IAT ground
31	IAT	White	Intake air temp sensor input
32	VCC	Yellow	+5V Power of Throttle position sensor
33	TPS	White	Throttle position sensor signal
34	GND	Green	Ground of throttle position sensor
35	Per_SW	White	Performance switch
36	GND	Green	Ground
37	CDI-PG	White	Control signal of CDI

1.12 Mount the Harness

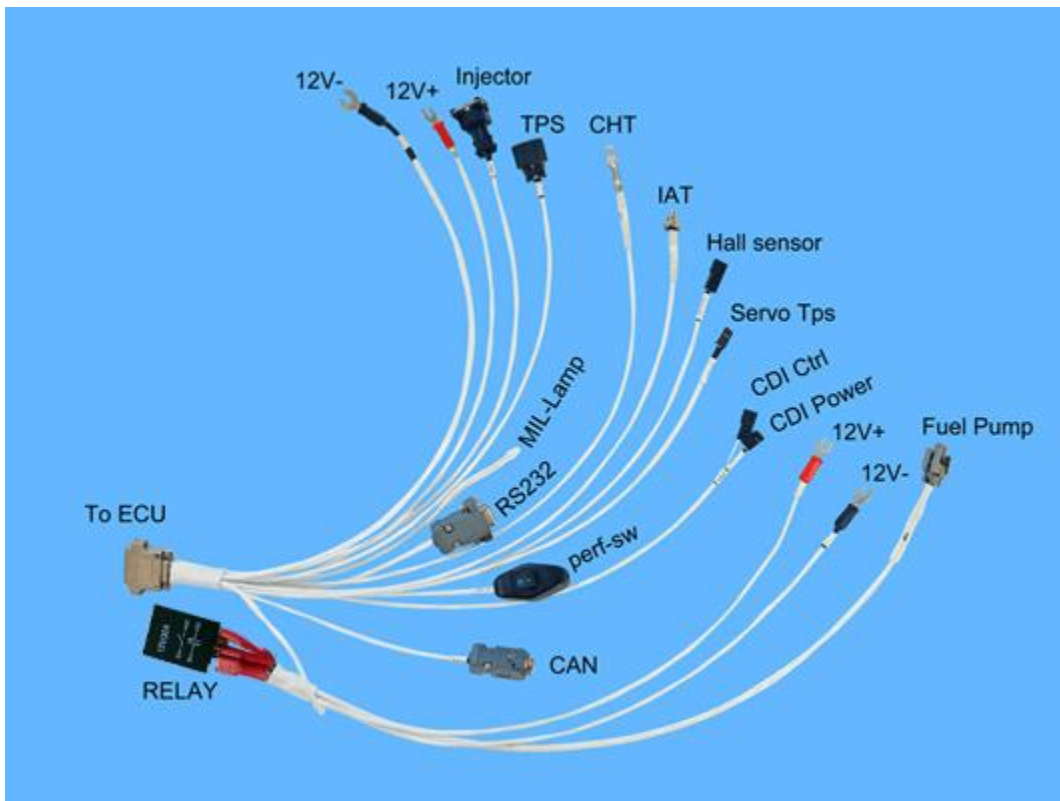
Please find the suitable place to mount the harness.



The Wire Length:

From "ECU main connector"	From the main Connector	Length
	12V-	500mm
	12V+	500mm
	Injector	500mm
	TPS	500mm
	CHT	500mm
	IAT	500mm
	Hall sensor	500mm
	Servo Tps	500mm
	CDI Control	500mm
	CDI Power	500mm
	MIL- Lamp	200mm

	RS232	200mm
	Perf-SW	200mm
	CAN	200mm
From "Relay"	12V+	500mm
	12V-	500mm
	Fuel Pump	500mm

Notice, the Length does not include the length of connector, and it is only the wire length. Usually, the error range is 10mm.

1.13 Optional prime switch function

There is a prime switch on the EFI harness. The function is to manually trigger the EFI to inject a little fuel before you start the engine by hand.

When engine is ready to start, you press it to the "I" position, it will inject a little starting fuel. It only injects one time even if you leave it at "I" position. If you want to inject more fuel, you can cycle this switch, meaning back "O" position, and then press it again to "I" position.



Chapter 2 ALM-ECU integration for tuning

2.1 Install the wideband O2 sensor

You need drill the hole and weld the bung in the exhaust and to install the O2 sensor.

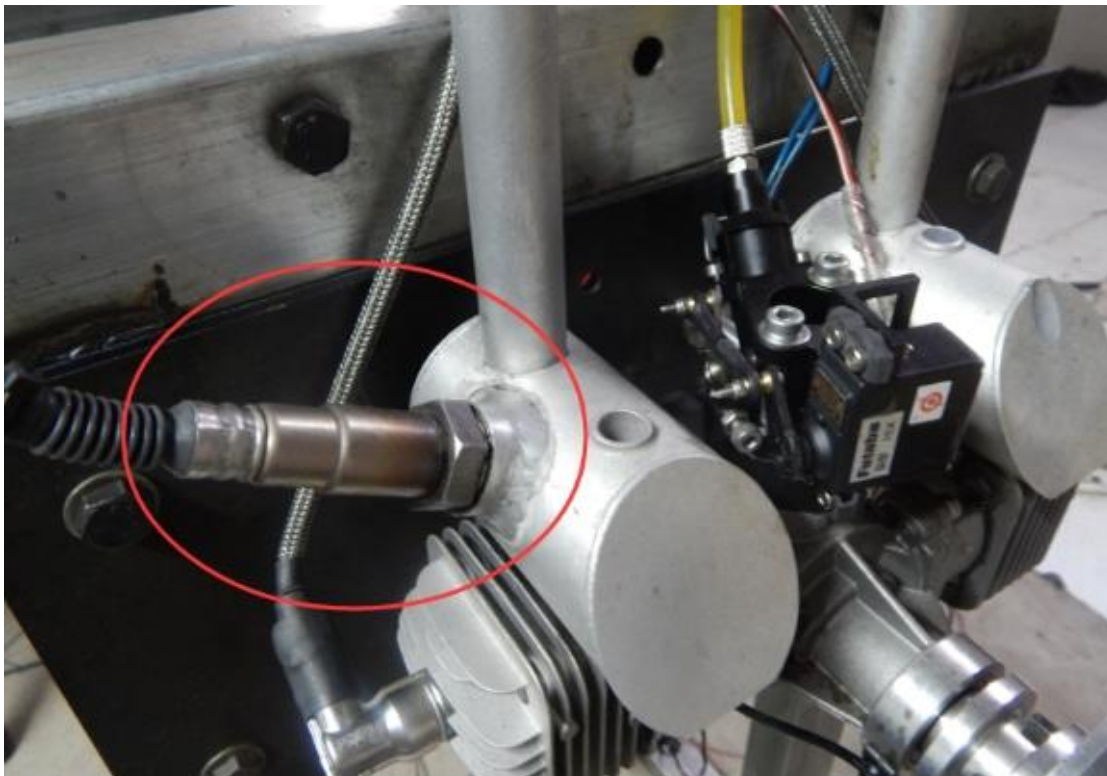

2.2 Connect the ALM to ECU

2.2.1 Connect the ALM to ECU via Performance switch

ECU can read the Lambda (AFR) from the wideband controller with LSU4.9/ADV sensor (ALM), you need connect the linear analog output of wideband controller to the ECU

harness, then ECU can read the real-time lambda, and you can use the lambda to tune the fuel mapping of EFI.

We use the "Perf-SW", performance switch, wire to connect the ALM input. Most of EFI has this "Perf-SW" switch, you need tap the linear output of wideband controller to the wires of performance switch.

Please connect it by using following pictures.

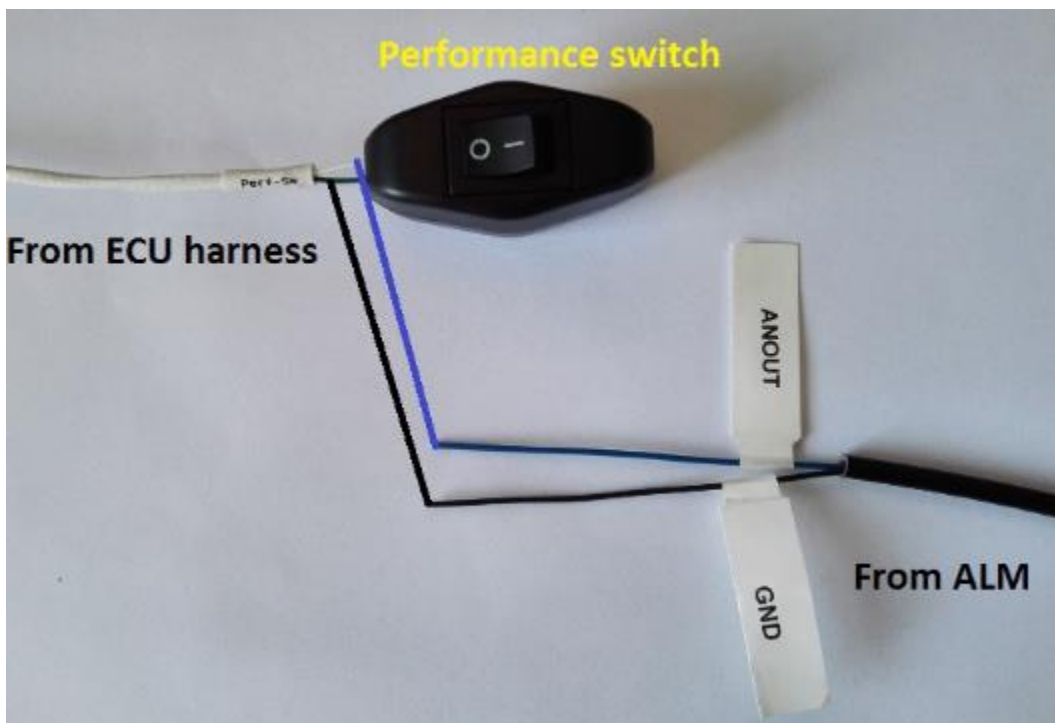

Connection

Connect the ANOUT to the white wire of performance switch

Connect the GND to the green wire of performance switch.

Warning: You need set the performance switch be "O" side, if not; it will not read the real-time lambda correctly

Please do a modification to match the ALM in CAL file.

Please set the variable: **CV_SSWO2 = 1.**

2.2.2 Connect ALM-CAN to ECU via CAN bus

If you order the ALM-CAN units from Ecotrons, which can be connected to ECU directly. ECU can receive the data from ALM-CAN by broadcasting and analyze the data to get the value about Lambda, AFR and O2%.

You need to modify the following calibration variable to match the ALM-CAN in CAL file.

Please set the variable: **CV_SSWO2 = 3.**

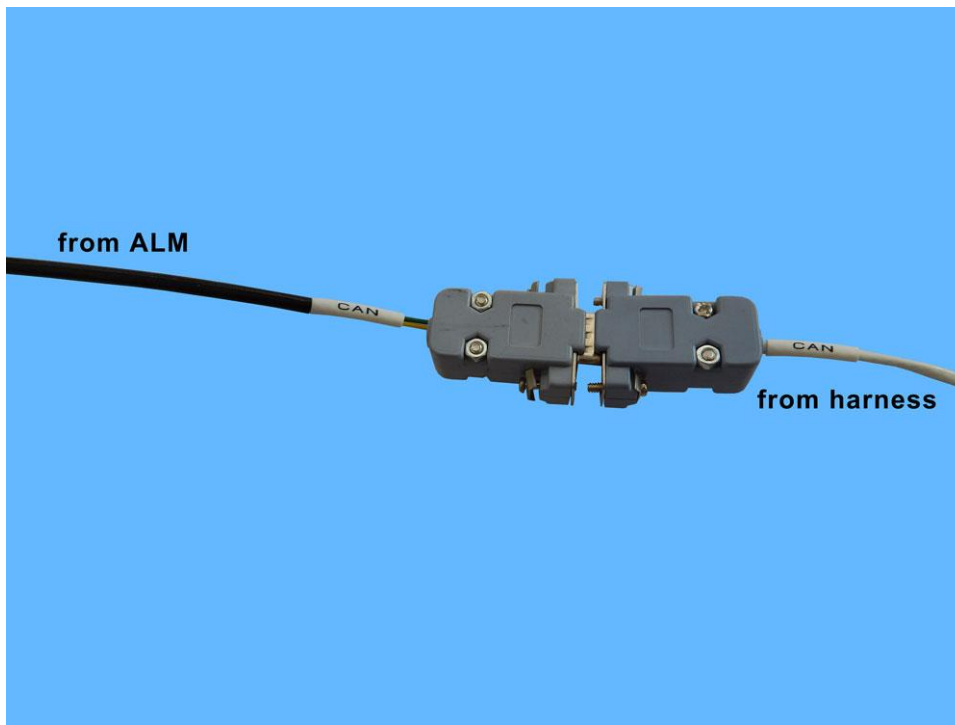

Chapter 3 Broadcast protocol

3.1 ECU broadcast data list on RS232

You can read some parameters of engine from the RS232 serial cable by using your equipment.

So we provide the protocol to you for using this function.

Variables: RPM, MAP, TPS, ECT, IAT, O2S, SPARK, FUELPW1, FUELPW1, UbAdc.

Note: Enable the broadcast data function; please tune the CV_APP to be 128, then burn to ECU.

Calibration: CV_APP=128

If you don't have this variable, please connect us.

The data format is hex, the baud rate is 115200, no parity bit, 8 data bits, 1 stop bit, time interval 100ms.









Please go to our website to download the document:

<http://www.ecotrons.com/support/>

Download the Ecotrons Broadcast data list.

See the mark of the Ecotrons Broadcast data list as shown below.

[Support](#)[Latest Software – Free Download](#) ^[UAV EFI & Component Manuals](#) ^[EFI System Manuals](#) v

- [EcoCAL User Manual – v1.4](#) 
- [Ecotrons EFI Software Strategy Book – v2.1 \(new\)](#) 
- [Ecotrons EFI Installation Manual – v2.8 \(new version\)](#) 
- [Ecotrons EFI Tuning Guide – v2.9.7\(new version, a lot of details!\)](#) 
- [Flash GUI User Manual – v1.4](#) 
- [DroidCAL Phone App manual – v1.4 \(new\)](#) 
- [SimMotor Manual – v2.3.1](#) 
- [Ecotrons EFI – Broadcast data on RS232 – v1.4](#) 

3.2 ECU broadcast data list on CAN bus

3.2.1 The CAN Baud rate setting of ECU

Our ECU and tuning software (EcoCAL) support the CAN communication, you can change the baud rate by yourself.

Note: There should be a 120 ohm resistor between the CAN wires, and our ECU doesn't have the 120 ohm termination resistor, so you need add it by yourself in the CAN connector, see below picture

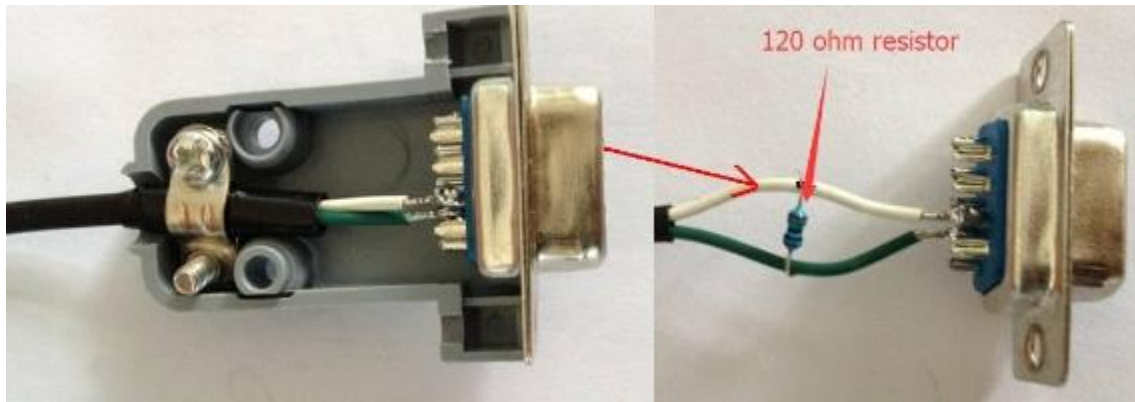

The calibration variable is “**VAL_CAN0_BaudRate**”, you can find this variable in Advanced.

The default is 250k, so **VAL_CAN0_BaudRate = 4**.

VAL_CAN0_BaudRate

/ CAN bus baud rate 3--500k, 4--250k, 5--125k, 6--100k, 7--50k, 8--20k, 9--10k, 10--5k */*

3.2.2 Can bus broadcast

Please go to our website:

<http://www.ecotrons.com/support/>







Download the Ecotrons UAVCAN Protocol.

See the mark of the Ecotrons UAVCAN Protocol as shown below.

Support

Latest Software – Free Download ^

UAV EFI & Component Manuals v

- Ecotrons UAV EFI component specs -v1.6 
- UAV engines EFI installation manual – v2.4 
- Ecotrons UAV EFI installation manual for DA150-V1.7 
- Ecotrons UAV EFI kit installation manual for 3W-56iB2 – v1.7 
- Ecotrons UAV EFI kit installation manual for DLE120 – v1.7 
- Ecotrons UAVCAN Protocol – V1.5 

Chapter 4 Communication Settings

How to install the provided EcoCAL software to your computer?

For details on how to use EcoCAL software, please refer to the EcoCAL Manual, downloadable here:

www.ecotrons.com/support

Run EcoCAL, you will see below windows:

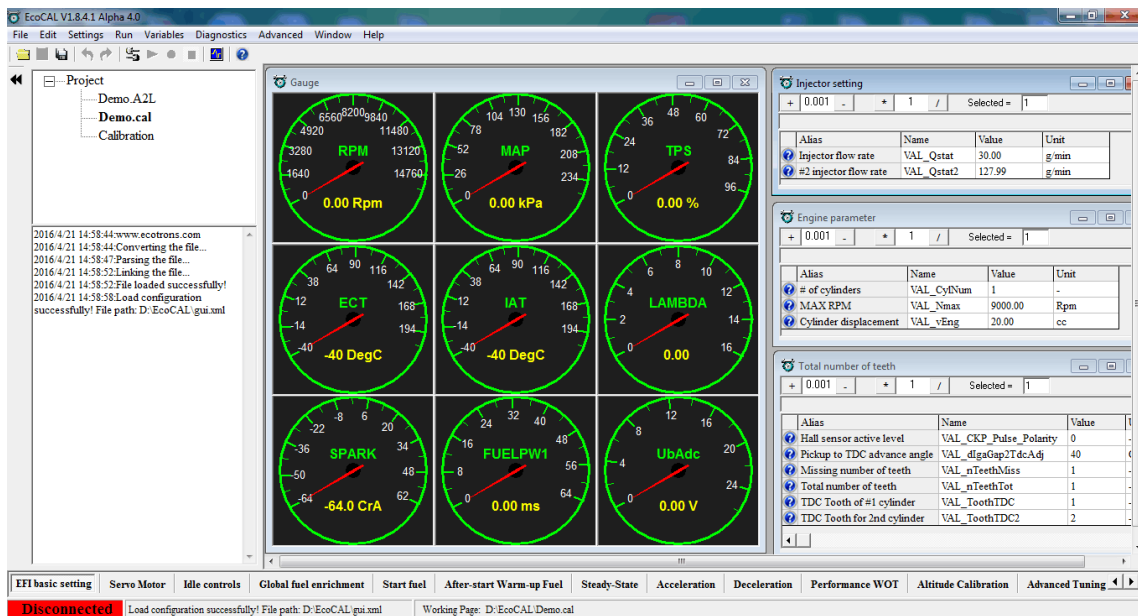

Connect ECU to laptop:

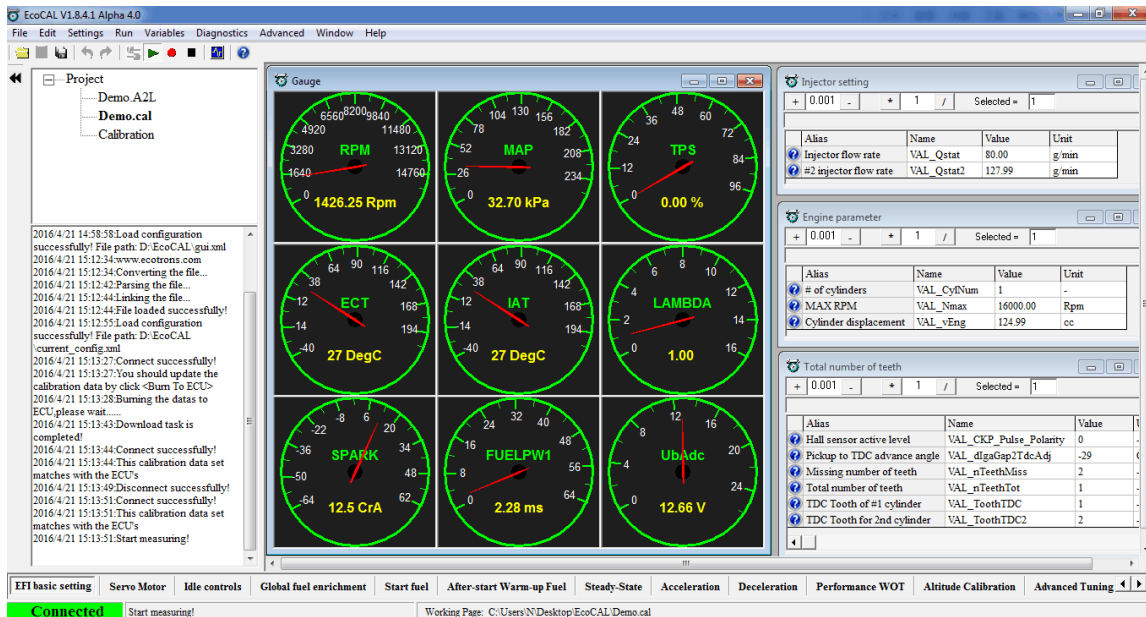

Read DTC:

Go to Menu à Diagnostics ->ECU Diagnostics

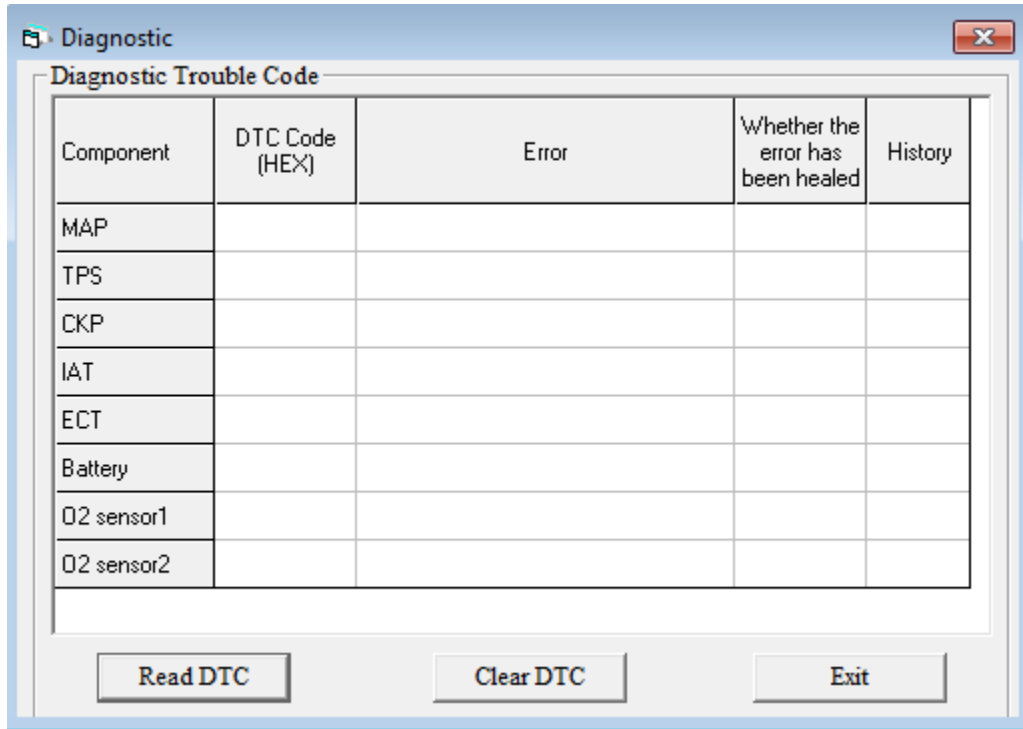

Click "Read DTC":

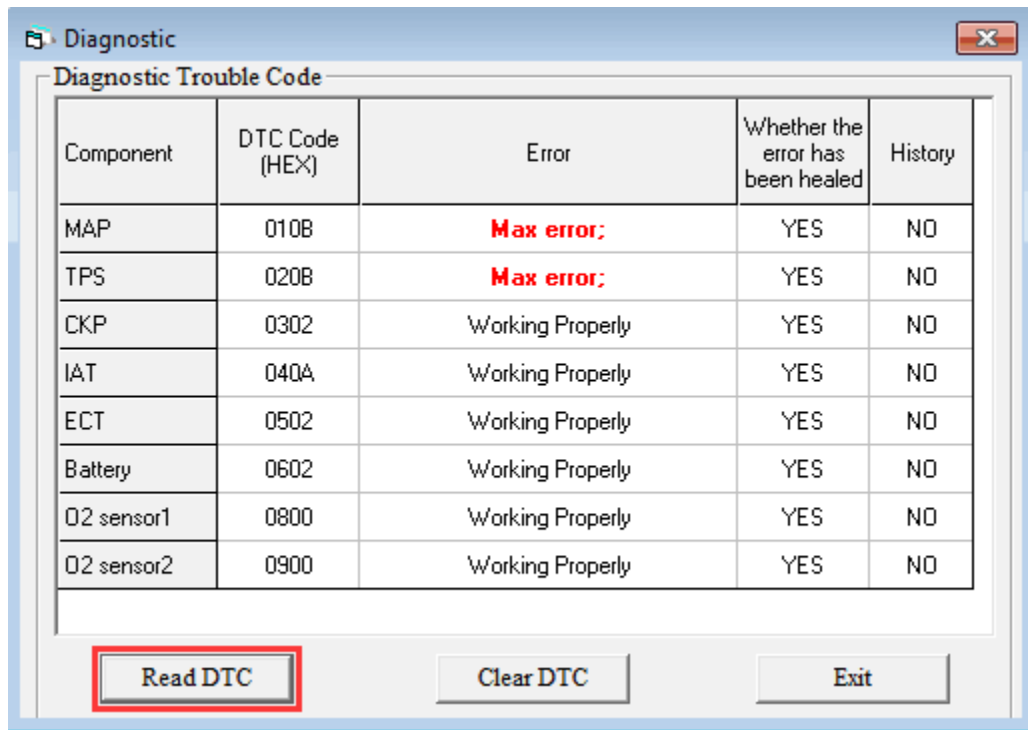

Click "Clear DTC":

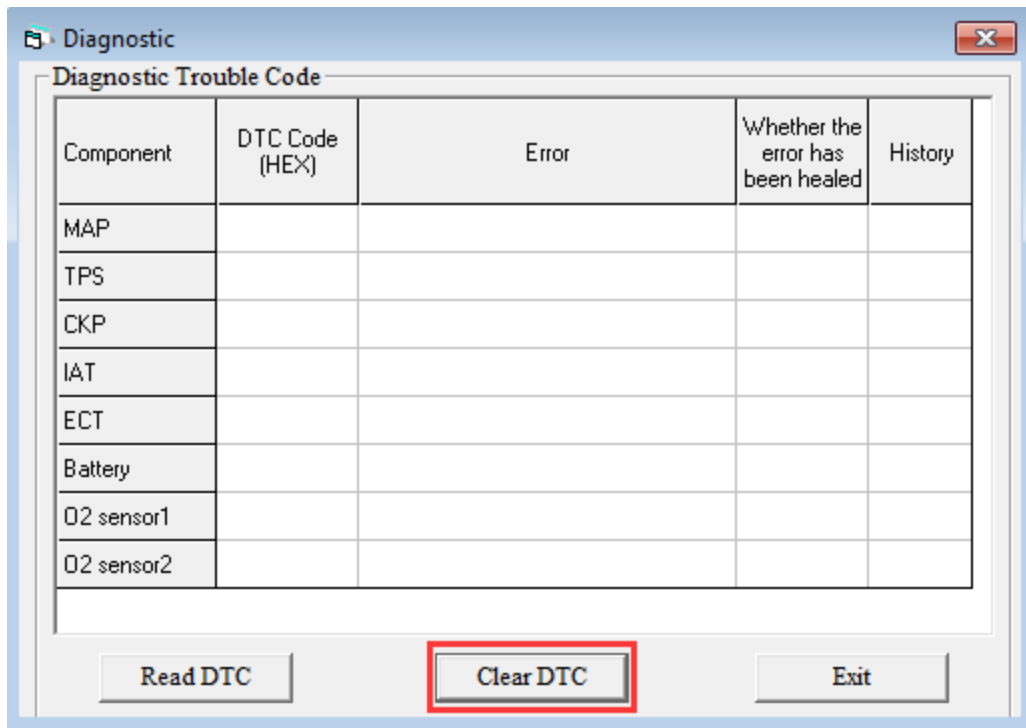

You should select the communication mode first based on which way you use COM , CAN or Ethernet.

In default, we provide the COM RS232 cable and USB adapter, so you can use the COM or USB for communication.

Go to menu->Settings->Communication Settings:

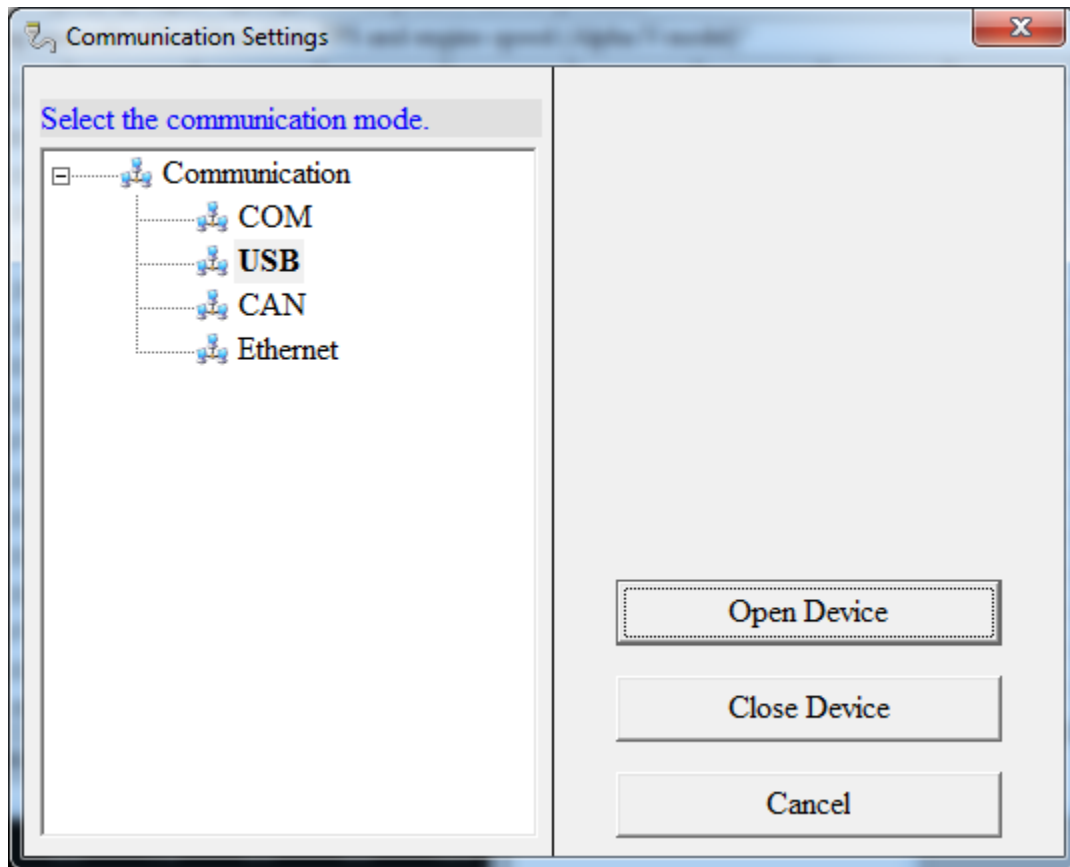

Note: By default, EcoCAL uses USB communication mode (**Note: insert the Ecotrons' USB adaptor into the laptop first for USB mode**). This configuration is consistent with most of the computers.

4.1 COM communication mode

If the user is using the **COM** mode (**Note: for this mode, your laptop need to have a built-in COM port**). Select COM and set the COM port, the default COM port is **COM1**.

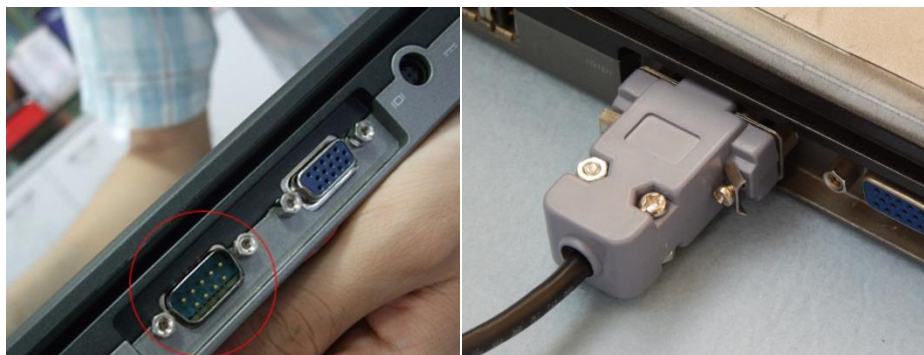

Built-in COM port (9-pin)**RS232 cable**

The default baud rate is 115200, which is the fastest of the serial comm. rate of the PC. It is not supposed to change.

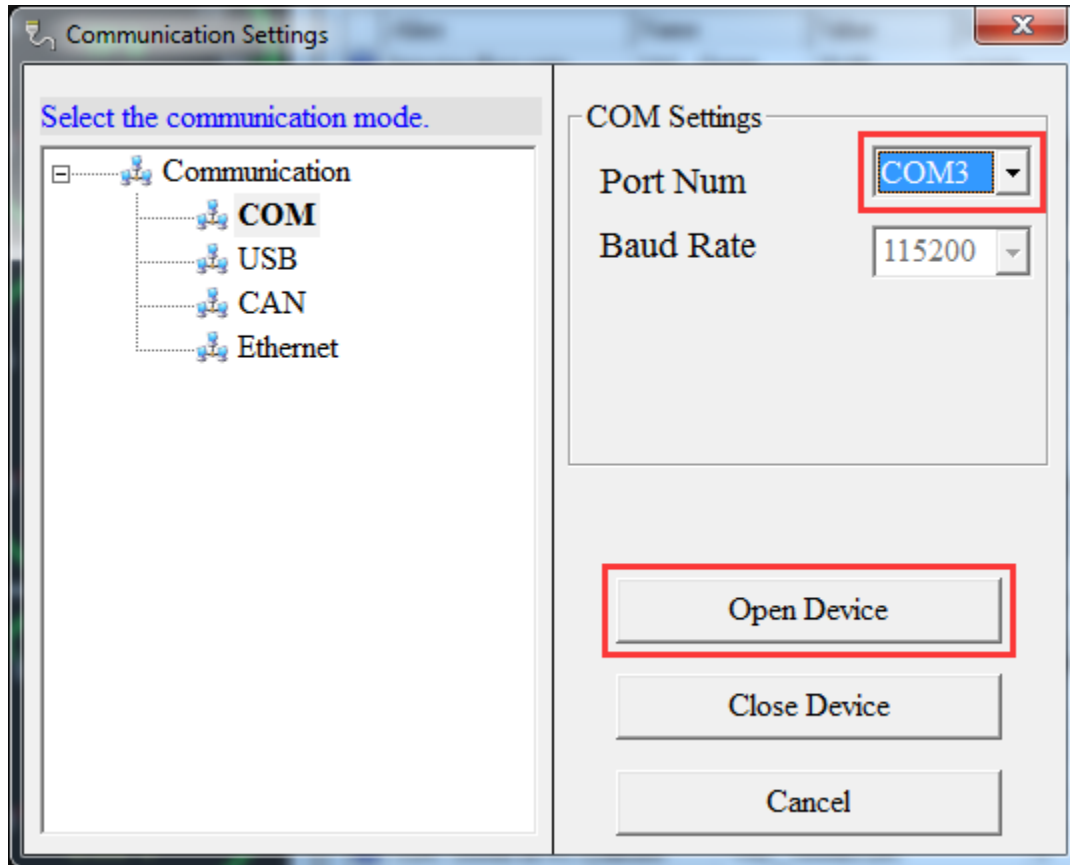

4.2 USB communication mode

Most new computers do NOT have a built-in COM port any more. You should insert the USB adaptor (Ecotrons' USB Adaptor) to the laptop, and then select the **USB** in the communication settings window of EcoCAL.



Note: We do not support the 3rd party USB-RS232 adapters, even though they might work sometime. The problem is that those consumer electronics rated USB adapters only works in a noise-free environments. This means, once the engine is running, it generates a lot of electronic magnetic noises. And those USB adapters, though looking pretty, will not stay working when you are driving. That's why we developed our own.

Note: Make sure the connection between laptop and USB adaptor (Serial communication cable) is **FULLY** plugged in.

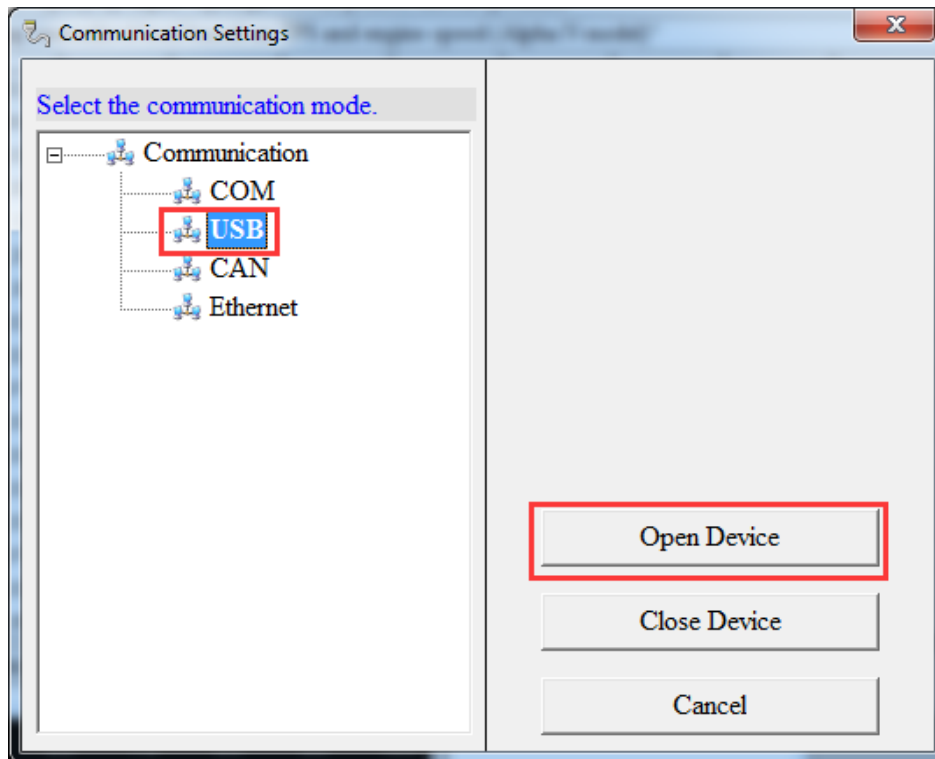

Choose the USB first, and then click “Open Device”.

4.3 CAN communication mode

Our custom ECU support the CAN communication, if the ECU of EFI system supports the CAN communication, you can use this communication mode to connect ECU.

You need to choose the CAN device Type, Baud Rate, after finishing setting, then click “**Open Device**” to open the CAN device.

And if you don't want to use the CAN, you also need to click “**Close Device**” to close the CAN device.

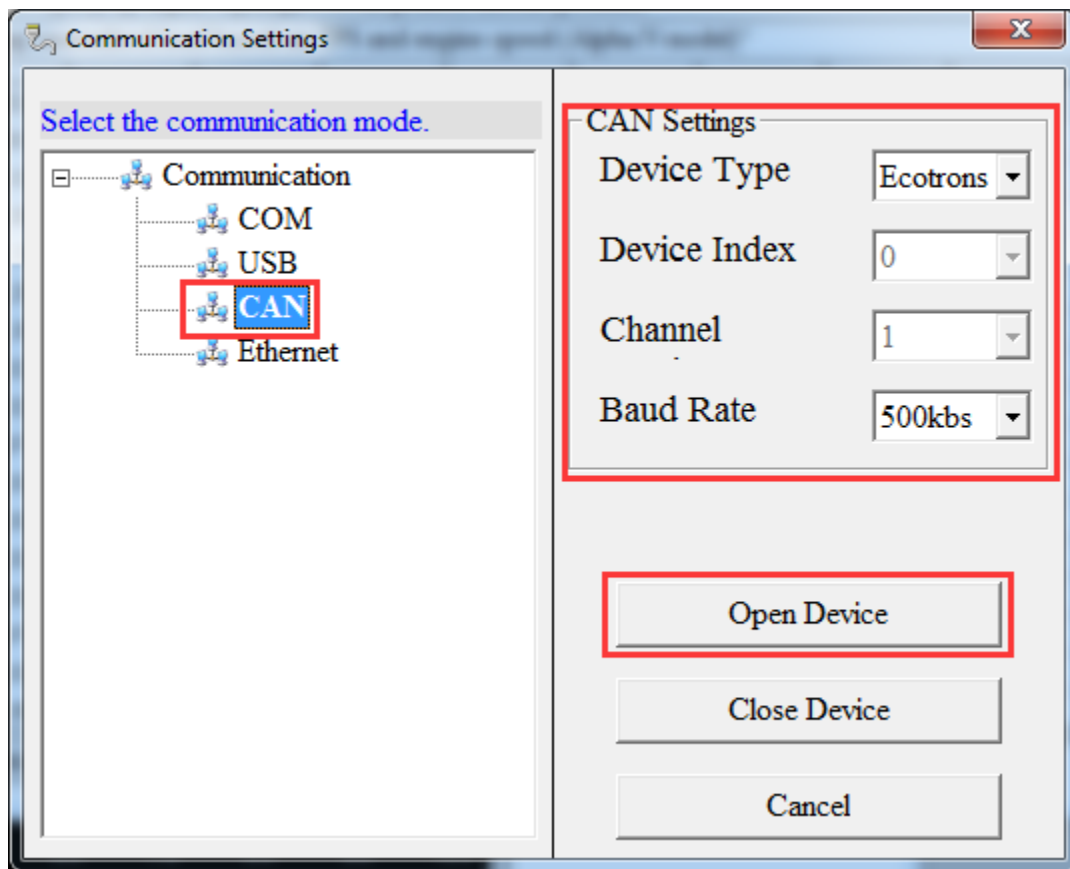

4.4 Ethernet communication mode

Our custom ECU also support the Ethernet communication, if the ECU of EFI system supports the Ethernet communication, you can use this communication mode to connect ECU.

You need to make Ethernet connect laptop with Ethernet cable, choose the Ethernet device Type, click "**Search Module**", after IP and Port appear, then click "**Open Device**" to open the Ethernet device.

And if you don't want to use the Ethernet, you also need to click "**Close Device**" to close the Ethernet device.

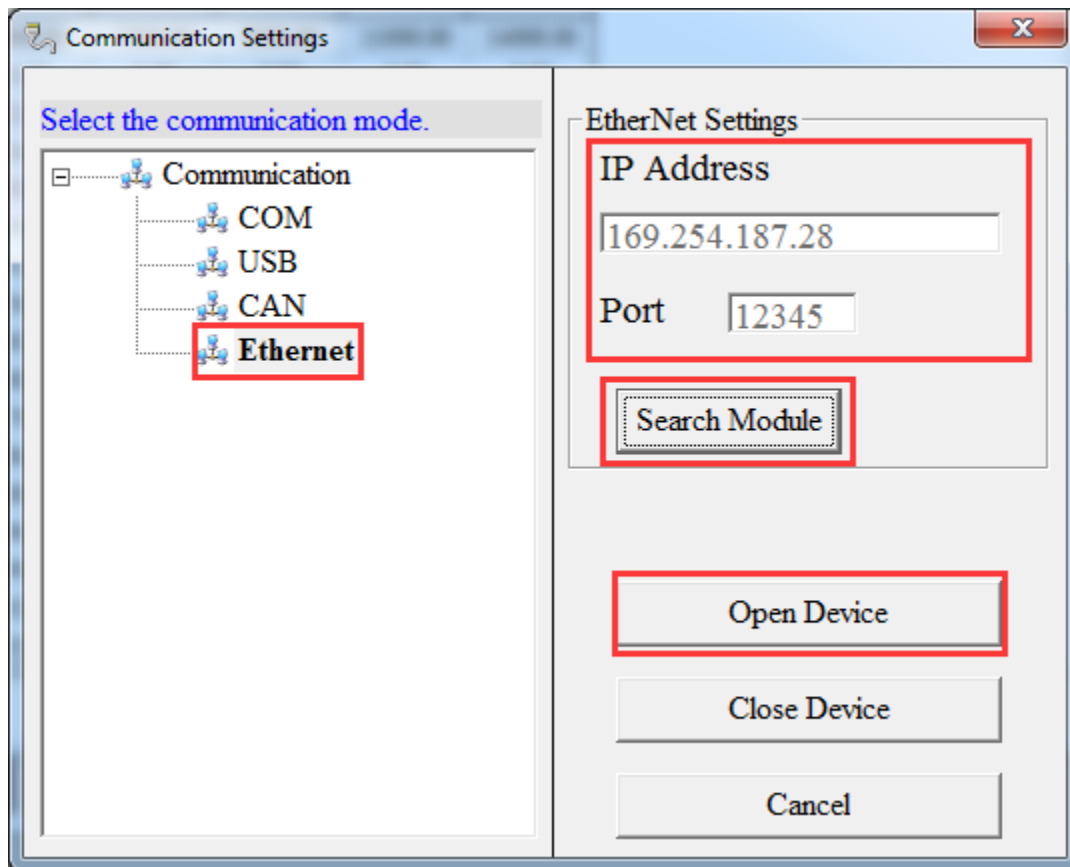

Note: when you click the "Open Device", if the equipment is existed and working, the message will pop up, "Open device successfully!" Then you can connect to ECU.

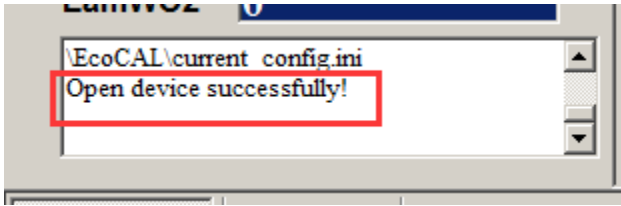

Chapter 5 Initial test after the installation

Before you do the initial test of the EFI kit, make sure the installation is done as the previous section.

Key-on and **KEY-ON ONLY!**

You should hear fuel pump noise running for a few seconds, if this is not happening, you must have some wiring problem. Re-check all your wires! If every wire is sure correctly connected, then the ECU may have a problem.

If you hear the fuel pump running and then stop, this indicates the ECU is working. Now you can fill the fuel tank with the regular gasoline.

Repeat the above step 3 times, to make sure the fuel supply lines are filled up with fuel. No air pocket! No bubbles!

Sometime, you have to manually purge out all the air bubbles in the fuel supply system, because it is possible that if the fuel pump itself has a lot bubbles in there, it could not pump fuel at all, it is only spinning like idle without load. In this case the noise of fuel pump is little higher pitch than with fuel pumping. In this case you will not be able to start no matter what, because no fuel pumping. If you have any doubt that the fuel supply system has some air pocket or air bubbles, you can un-plug the high pressure fuel line, pointing it into a bottle, and key-on, you should see fuel sprout out if fuel pump is working and no air bubbles.

In many cases, you can visually see the fuel flow out of the fuel pressure regulator and return back to the tank if the fuel supply system is working normally. This is another indication you can check.

After you make sure the fuel supply system is working normally, try to rotate the propeller to start the engine.

First time you start the engine, there may be still some air bubbles in the fuel supply system needs to be purged. So don't be surprised that the first start takes longer, or even you need to start multiple times to be successful.

If the engine does not start, go to the next section for diagnosis.

After the engine starts, if it's rough idling; please open a little throttle, make the engine is at idle, then tune the fuel injection.

After the idle stabilizes, run the engine in a steady state (constant throttles or constant speeds) at different throttle/speeds. Then to tune the fuel maps to get the best performance.

Then you can try different transient conditions, like fast opening of the throttle, etc.

My engine does not start, why?

1) Have you followed the installation manual completely?

1.1) Can you tell that the ECU is controlling the fuel pump?

1.1.1) when you turn on the key, do you hear the fuel pump running for a few seconds, and then stop? If not, you have wiring issues.

1.1.2) Key-off for 3s, and key-on, do you hear the fuel pump running for a few seconds, and then stop? If not, you have wiring issues.

1.1.3) Every time when you try to start the engine (engine spins), do you hear the fuel pump running until engine stalls? If not, your wiring has issues.

1.2) Do you have the fuel pump installed correctly?

1.2.1) is the fuel pump lower than the tank? The fuel pump must be lower than the tank to avoid fuel starvation. The fuel pump can be higher than the injector, if limited by the space.

1.2.2) is there bubbles in the fuel line? If yes, please move the bubbles out of the fuel line first.

1.2.3) Do you have a fuel return line back to the fuel tank? Our EFI kit currently needs a way to return the fuel to the tank.

1.2.4) is there impurity in the gasoline? Check your fuel filter.

1.3) Do you have the ignition pick up sensor connected correctly?

1.3.1) Do you have a correct pick up signal input to ECU (Hall sensor wire) on the harness?

1.3.2) Do you have the ground wire of pickup sensor connected to ECU ground wire?

1.3.3) Are you using the stock ignition system (to isolate the starting problem, please use the stock ignition system)?

1.3.4) Can you tell the spark plug is firing when you try to start?

2) Do you have the MIL Lamp on (if your harness comes with a MIL Lamp installed)? If yes, go to "EcoCAL installation".

3) Install the EcoCAL (coming in the CD, or downloadable at our website):

3.1) EcoCAL does not support Windows Vista at this moment. Please use Windows XP (the most tested environment), or Win7, Win8.

3.2) you installed the EcoCAL into your computer, but it does not talk to the ECU: please check your USB adaptor is fully plugged in. And EcoCAL communication setting is set as USB.

Or better: use an old computer which has a built-in COM port to rule out the USB converter problem.

3.3) establish the communication between the EcoCAL and the ECU: **Go to menu->Run->Start Measuring**, you should see the gauges starting to show values.

3.4) Read diagnostic trouble codes by go to:

Go to menu->Diagnostics->ECU Diagnostics

4) With the EcoCAL communicating with ECU, do the below tests:

4.1) Try to start the engine (with the engine spinning), Read the variables in EcoCAL:

4.2) Does the signal "RPM" changing from 0 to some value > 300rpm?

5) To rule out the problem of the ignition pickup sensor, do the below tests:

5.1) disconnect both CKP wire and GND wire from the ignition pickup sensor and tape them;

5.2) make sure the stock ignition system is untouched;

5.3) Try to start the engine, and check the below:

5.4) Does the signal "RPM" changing from 0 to some value > 300rpm?

5.5) if the above is NO, you could have some wiring problem. If the above is YES, you could have fuel supply issue: air bubbles in the fuel lines, or fuel clogged somewhere.

With all the above questions and tests done, you still cannot figure out why the engine does NOT start, please contact us directly:

info@ecotrons.com

Chapter 6 How do we know the fuel injector flow rate

See the mark of the fuel injector as shown below,



This fuel injector flow rate is 248g/min. **Note: It does not recommend removing the injector cap, as it may lead to damage the injector cap.**

Refer to the comparison table,

Item	MEV1-030	MEV1-038	MEV1-060	MEV1-080	MEV1-128	MEV1-190	MEV1-248
Flow (g/min)	30	38	60	80	128	190	248

If there is no mark on the fuel injector, contact us for more information about the fuel injector.

Chapter 7 UAV EFI Maintenance

UAV EFI check list before flight:

- a. 12v power supply
 - i. Before each flight, check the 12V power supply to EFI, and make sure the voltage is 12V or higher.
 - ii. Check the 12V negative wire is grounded and shares the same ground as the engine block.
 - iii. Check the charging system is functioning, and no deficiency (with the engine running).
- b. EFI
 - i. Check the main connector plugged in and secured by screws, before each flight;
 - ii. Check all wires are neat and secured, before each flight;
 - iii. Check the ECU is mechanically secured; cushioned from severe vibration, not directly exposed to water or contamination, etc.
 - iv. Before each flight, check the correct version of software, and correct version of calibration by connecting to the laptop and start the measuring. If the firmware is incorrect, you will be warned by “software mismatch ...”. If the calibration is incorrect, you will be popped up with “burn to ECU ...”. Make sure your laptop has the CORRECT software (A2L file) and correct calibration (CAL file) opened in EcoCAL before you do this check.
- c. Hall Effect Sensor
 - i. Check the sensor wires and sensor connector before each flight;
 - ii. Check the RPM reading before each flight, in EcoCAL, by spinning the propeller and read the RPM gauge. If the engine starts and runs stably, the Hall sensor is OK.
 - iii. If there is no RPM reading, and/or there is no injection, the first thing is to check the Hall sensor. You may need to swap a new Hall sensor to verify.
- d. BARO Sensor

- i. Before each flight, check the brass tube on the ECU is not blocked (which is for the on-board Baro pressure sensor)
 - ii. Before each flight, check the “MAP” gauge reading, in EcoCAL. It shall match the ambient pressure, like 101kPa, or 14psi.
- e. TPS Sensor
 - i. Check the sensor wires and sensor connector before each flight;
 - ii. Check the TPS reading before each flight, in EcoCAL. Use servo to move the throttle from 0-100% and back to 0% and verify in EcoCAL the TPS gauge is following.
- f. IAT
 - i. Check the sensor wires before each flight;
 - ii. Check sensor reading before each flight, in EcoCAL. IAT gauge reading should match the engine surrounding temperature. Note, you can change the reading to Fahrenheit by going to menu -> setting -> toggle units.
 - iii. Check the sensor integrity physically every 50 hours, make sure no crack, and no carbon residual, etc.
- g. Temp Sensor (CHT)
 - i. Check the sensor wires before each flight;
 - ii. Check sensor reading before each flight, in EcoCAL. ECT gauge reading should match the cylinder head temperature. Note, you can change the reading to Fahrenheit by going to menu -> setting -> toggle units.
 - iii. Check the sensor integrity physically every 50 hours, make sure no crack, and no carbon residual, etc.
- h. Fuel Injector
 - i. Check the injector wires before each flight;
 - ii. Check the fuel injection atomization every 50 hours. This means, pull out the injector from the throttle body, spin the engine, check the injection squirt and make sure it is “misty”.
 - iii. If it is not misty, check 2 things: #1: check the fuel pressure, with a fuel pressure gauge ; #2: if fuel pressure is stable at 3 bar or 43psi, then swap the injector and check again from step (i).
- i. Throttle Servo

- i. Check the servo wires and connector before each flight;
 - ii. Before each flight, visually check the servo assembly, no cracks, and no loose parts.
 - iii. Before each flight, visually check the throttle is synchronized with the servo movement. If you see some “lag” or “dead zone” between the servo and throttle, you need re-adjust the mechanical link between the servo and the throttle.
 - iv. If you have a TPS sensor installed, you only need to check that the servo can drive the throttle from 0 to 100% and then back to 0%. Read the TPS position in EcoCAL when you are moving the servo.
 - v. If you do NOT have a TPS sensor installed, and you are using the servo control PWM signal as equivalent TPS signal, then you need to verify the servo PWM signal has a linear relation to the equivalent TPS signal. The way to verify is to use servo drive the throttle from 0-100% and back to 0%, and monitor the TPS gauge in EcoCAL, make sure the TPS gauge is moving proportionally with the servo movement (slowly).
 - vi. If you use the servo control PWM signal as the equivalent TPS signal, and if you re-adjusted the servo-throttle linkage, you must “re-calibrate” the servo-throttle linear relation. See manual for how to.
 - vii. Every 200 hours, change to a new servo.
- j. Fuel Pump
- i. Before each flight, check the fuel pump wires and connector before each flight;
 - ii. Before each flight, check the fuel tank which should have enough fuel, and fuel lines are fulfilled with fuel and no air pocket. If you see any air pocket, disconnect the fuel line, and purge it out.
 - iii. Visually check fuel lines, and make sure no severe bending or kinks in the lines.
 - iv. Key-on, you should hear some fuel pump running noise for a few seconds, and you shall visually see the fuel is flowing through the whole fuel supply system. Or simply, you shall see fuel returning back to the tank (at the fuel pressure regulator returning line). If

- you hear the fuel pump running noise but no fuel flowing, you shall check the fuel supply to the pump, or air pocket in the lines.
- v. Every 50 hours, check the fuel pressure with a fuel pressure gauge, and make sure the fuel pressure can be maintained at 3 bar or 45psi at all RPMs, including the WOT (wide open throttle running).
- k. Fuel pressure Regulator
 - i. Check the same thing as you check the fuel pump;
2. Throttle body, what needs to be maintained.
 - i. Before each flight, check the throttle body is mechanically secured to the engine , no cracks, no loose bolts;
 - ii. Every 50 hours, take off the throttle body, and visually check the integrity of the throttle body, no cracks, no carbon, no loose parts, etc. Clean it if there is any residual.
 - iii. Every 50 hours, check the throttle body gaskets, no worn, no leaking.
 3. Ignition module (CDI).
 - i. Before each flight, check the wires and connector to the CDI module.
 - ii. Before each flight, if the engine does not start, and you know the fuel system is OK, then check the ignition system: pull out the spark plug(s), hold it against the engine block, spin the engine, and check whether there is spark. If there is no spark at all, and the spark plug looks clean, then check the CDI module. You may need to swap to a new CDI module to verify. If the spark is too weak, then swap to a new spark plug and check again, if still the weak spark, then check the CDI module.
 - iii. Every 50 hours, check the spark plugs. If dirty or worn, swap them.
 4. Air filter.
 - i. Change Air Cleaner every 50 hours or sooner as needed;
 5. Engine life
 - i. Typically a UAV engine has a life expectancy of 200 hours, check the engine manufacture data;

6. Clean engine
 - i. Need to de-carb engine every 50 hours when using 100LL Fuel;
7. Engine exhaust and muffler
 - i. Mufflers should be soaked in cleaner every 50 hours and dry before use;
 - ii. Exhaust(s) inspected after and before each flight

8. Multiple-Check

Does the fuel pump turn on for a few seconds when powering on the ECU?

Do you hear the relay ticking when power on the ECU?

Does engine start normally?

Is there a RPM reading by ECU?

Is there any fuel injection when engine cranks?

When the fuel pump is running, (with key on), do you see fuel flowing in the fuel line? Are there bubbles in the fuel hose?

Power on the EFI system, and see if the MIL lamp (LED) is on, it means there is an error in the system and please use EcoCAL to read DTC if the MIL lamp (LED) is on.

Please visually check the throttle is synchronized with the servo movement again.

Please check if the communication of the “auto-pilot” is normal.

Before each flight, check all the above items of UAV EFI system again, and make sure they are all normal. You also need to check if the all other facilities of UAV are good.